

Traditional Sash Windows

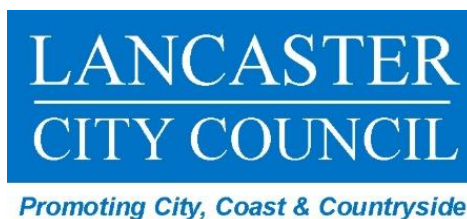

Planning Advice Note 14

March 2024



Contents

<i>Introduction</i>	3
<i>Listed building consent</i>	3
<i>Planning permission</i>	3
<i>Legislation and policy</i>	4
<i>Evolution of sash windows</i>	5
<i>Typical sash window types by period</i>	6
<i>Maintenance and repair</i>	7
<i>Thermal upgrading</i>	7
Draughtproofing	8
Secondary glazing	8
Slim double glazing	9
<i>Replacement windows</i>	10
Slim double glazing	10
Double glazing in non-listed buildings	11
<i>Ventilation</i>	12
<i>Materials</i>	13
<i>Sash horns</i>	14
<i>Glass</i>	14
<i>Paint</i>	15
<i>Ironmongery</i>	15
<i>Burnt sand mastic pointing</i>	17
<i>Appendix A: Sash window sections:</i>	18
<i>Appendix B: Typical glazing bar mouldings</i>	54
<i>Appendix C: Sash horn profiles</i>	56
<i>Further advice</i>	58

This guidance document was produced as part of the Lancaster High Streets Heritage Action Zone (HSHAZ). This was a four-year programme of heritage-led investment, with a focus on capital works, community engagement and cultural programming, which ran from 2000-2024. It was centred in the Mill Race area of Lancaster and was led by Historic England and Lancaster City Council, with support from a number of local partners.

Traditional Sash Windows

Planning Advice Note 14 (PAN)

Introduction

Windows help to define the character and appearance of a building. They are sometimes referred to as the 'eyes of the building'.

Their size, shape, profile, glazing, method of opening and fittings all make an important contribution to their character.

The emergence of the sliding sash window at the end of the seventeenth century, has been described as "visually one of the most momentous innovations in the whole history of our architecture".¹ They remained in popular use for over 200 years, and their differing styles demonstrate the development in design and manufacturing during that time, as well as changing practices and tastes.

It is crucial to understand their contribution to the building's significance and their condition before making any changes to them.

Where listed building consent and/or planning permission are required, then a heritage statement will also be required to support the application. This should demonstrate that the significance of the heritage asset(s) affected is understood, and the steps being taken to ensure that any harm caused to that significance by the proposal is avoided, but certainly minimised.²

If you are considering making changes to your windows, then you should seek advice from the Council's Planning Applications Team at the earliest opportunity to determine whether listed building consent or planning permission is required. If consent or permission is required, as well as Specialist Heritage Advice for listed buildings, there is a general pre-application advice service available to householders, in addition to that already offered for non-domestic development. Details of this can be found on the Planning section of the council's website.

Whilst further guidance is provided below, these services would consider the proposals on a case-by-case basis according to the site circumstances, which may vary from one building to another.

Listed building consent

If you own or are responsible for a listed building, then listed building consent will be required to replace or to alter the appearance of any windows, regardless of their age and style. This includes removing historic glass, installing secondary or any double glazing.

Planning permission

Please be aware that in addition to listed building consent, planning permission is always required for replacement windows in a listed building where the building in question is not classed as being a dwellinghouse, unless the replacement windows are like-for-like in appearance in all respects. Please note that a flat or apartment is not classed as a dwellinghouse.

¹ *The Pattern of English Building*, Clifton-Taylor, A., 1987, p. 391.

² Guidance on writing heritage statements can be found on the City Council's website:

<https://www.lancaster.gov.uk/planning/conservation/heritage-statements>

For listed dwellinghouses, planning permission would also be required where the materials proposed to be used are not of similar appearance or if the dwellinghouse is located within an Article 4 area (see below).

In conservation areas, planning permission is likely to be required where it is proposed to change from timber to uPVC in buildings, including dwellinghouses, because uPVC windows are not generally considered to have a similar appearance.³

Additionally, some conservation areas have 'Article 4 Directions' which usually apply to window alterations. This means that planning permission is required for changes to windows (other than like-for-like alterations). Article 4 Directions enable the Council to manage change which could be harmful to the character and appearance of the conservation area.

Legislation and policy

The *Planning (Listed Buildings and Conservation Areas) Act 1990* states that local planning authorities have a duty to have special regard to the desirability of preserving listed buildings and their features of special interest (Section 16(2)). The *National Planning Policy Framework* (2021 revision) states that in determining applications, local planning authorities should take account of "the

desirability of sustaining and enhancing the significance of heritage assets..." (para. 197), and that "...great weight should be given to the asset's conservation (and the more important the asset, the greater the weight should be)" (para. 199).

Lancaster City Council adopted its *Development Management Development Plan Document* (DPD) in July 2020. The DM DPD forms a key part of the new Local Plan for Lancaster District 2011 – 2031, guiding development within the local planning authority area by setting out the detailed planning policies which planning officers use to make their decisions on planning applications. Policies DM37-DM42 deal with development affecting the historic environment.

All planning applications must be determined in accordance with the provisions of the Local Plan unless material considerations indicate otherwise.

This guidance document is a Planning Advisory Note (PAN). A PAN provides guidance on procedure or design advice, rather than policy interpretation. As such, they are not formal parts of the Council's Local Plan. However, applicants are advised to use the guidance in this PAN to help shape and inform their proposals.

³ The dwellinghouse permitted development test in Schedule 2, Part 1, Class A (A.3 (a)) of *The Town and Country Planning (General Permitted Development) Order 2015* states that the materials

used in any exterior work must be of a similar appearance to those used in the construction of the exterior of the existing dwellinghouse.

Evolution of sash windows

Sash windows were the most popular type of window in this country for over 200 years. It is possible to find sashes which have been well maintained still working adequately 250-300 years later. Their elegant and practical design is still suitable for the present-day lifestyle. They offer a versatile way of ventilating a room, as well as offering a means of escape for Building Regulation purposes, where required.

Prior to the emergence of the sash windows in the late C17, leaded casements were the standard window type, often housed within stone mullions. Many examples of these earlier window openings can still be seen across the district.

It was the advent of Neo-classical architecture in England which saw the sash window rapidly become the window of choice. Their first use in England is thought to have been in the Palace of Whitehall, c. 1670. Classical windows tended to be taller than their width. Width could be achieved by placing two or three windows alongside one another. Their design suited the Palladian style of architecture with its strict principles of regularity, symmetry, and mathematical proportion.

The earliest sashes tended to have thicker glazing bars with smaller panes, and therefore more of them **(A)**. However, by the mid-C18, larger panes (using crown glass) with slimmer glazing bars became more common, and 'six-over-six' sash windows became the norm **(B)**. By c.1800 glazing bars had become incredibly slender **(C)**.

In 1784, the modest window tax which had been introduced in 1696, was increased to include every single window in a house above a threshold of six. This was so unpopular with householders that some did decide to block-up windows. However, it should not be assumed that all blind windows seen today were the result of this 'daylight tax'. More often, their purpose was to maintain the rhythm of openings in a façade where a window opening was not possible, such as in front of an internal partition.

The most significant changes to the sash window could be seen from the mid-C19 onwards. Glass-making techniques improved which meant that larger sheets of glass became more readily available **(D)**. Larger panes of plate glass, using fewer divisions, became common. Sash 'horns' also began to appear to strengthen the joints. Single panes of plate glass in each sash, 'one-over-one', became more widespread, offering lighter rooms with uninterrupted views **(E)**.

Sash windows remained in popular use for new buildings well into the C20, though multi-paned sashes also became fashionable once more as homeowners sought cosier interior environments.

Typical sash window types by period (see *Evolution of sash windows* above):

Early Georgian sash window (A), mid-Georgian sash window (B), late Georgian (C)

Victorian sashes (D) and (E). Edwardian sashes (F) often incorporated multi-panes, sometimes just to the top sash, and often used sash horns for aesthetic purposes.



(A)



(B)



(C)



(D)



(E)



(F)

Maintenance and repair

‘Repair not replace’ is the most sustainable approach and should be taken where possible.

Windows which are well maintained and repaired, when necessary, should not need replacing but should be capable of providing continuing service.

It is important to note that the quality of pre-1919 slow-grown timber likely to be high, and unlikely to be matched. It is therefore important to retain as much of the original timber as possible.

All efforts should also be made to retain historic glass. Modern float glass is perfectly flat and does not have the character of the historic glazing with its imperfections and distorted reflections which help give depth to the façade.

In order to prolong the life of your historic windows, it is advisable to check the condition of them annually. The most common issues are those involving water absorption therefore it is important that they are checked on a cyclical basis, paying close attention to the cills and lower parts of the frame since these are the most vulnerable.

Historic England and Historic Environment Scotland provide useful guidance for property owners. In [Sash & Case Windows: A short guide for homeowners](#) (HES, 2008). This includes a useful Inspection Checklist, along with a Guide to Specifying Repairs.

Decay

Where timber has decayed, it is possible to splice in, or ‘piece-in’ new elements, avoiding the replacement of the whole window. The new timber should be compatible with the original and match as closely as possible,

which is likely to have been slow grown deal (pine). Timber such as Baltic redwood or Douglas Fir are likely to be most suitable.

Where cills need replacing, or completely new elements, it would be advisable to use a durable hardwood or Accoya (see **Materials** below).

Thermal upgrading

Historic buildings have a key role to play in fighting climate change; “Reusing our buildings is one of the most effective ways to reduce carbon emissions and eliminate unnecessary waste” (*Climate Change Strategy*, Historic England, March 2022).

These buildings have survived because of their durability and adaptability. However, retrofitting appropriate energy saving measures can result in significant carbon reductions. It is therefore important to:

- Consider the whole-life carbon costs of any interventions, not just the potential saving in operational energy and carbon;
- Maintain and repair sympathetically with appropriate materials and techniques; and
- Consider improvements in the context of a ‘whole building approach’, i.e. considering whether proposed changes might cause other issues. For example, thorough draught-proofing might mean that controlled ventilation is required to prevent the build-up of condensation.

Interestingly, heat loss from windows represents less than 20% of the total loss, the roof and walls are largely responsible for the rest.⁴ Nevertheless, improvements should be made to their thermal efficiency.

[traditional-buildings/sash-windows-how-to-reduce-heat-loss/](https://www.historicenvironment.scot/advice-and-support/your-property/saving-energy-in-traditional-buildings/sash-windows-how-to-reduce-heat-loss/)).

4

<https://www.historicenvironment.scot/advice-and-support/your-property/saving-energy-in->



Figure 1: A sash window with operational internal shutters. Shutters greatly help a window's thermal performance.

There is much to be said for simply closing curtains (the thicker the better), blinds and shutters. However, the three main ways of upgrading existing windows are as follows, though not all will be appropriate in every case.

- Draughtproofing
- Secondary glazing
- Replacement of panes with slim double glazing

In the first two cases, any repairs should be identified and made to the windows before installing these measures:

Draughtproofing

This can be a very cost-effective way of improving a window's thermal performance, as well as being the least-intrusive option.

Research has shown that draught proofing can prevent leakage by between 33% and 50%, which could make a significant reduction to the heat required in a room.

It involves adding compression seals (usually at the top and bottom rails of the sash) and wiper seals (usually brush pile seals where moving parts slide past each other, such as at the sides and meeting rail of the sash).

Historic England's guidance, *Energy Efficiency and Historic Buildings: Draught Proofing Windows and Doors* (2016) provides helpful advice on how this might best be achieved.

However, it should be noted that some ventilation is essential to allow older buildings to breathe. It could cause issues where secondary glazing is also being employed as the condensation needs to be able to evaporate.

Secondary glazing

In 2008 research was carried out which showed that better results were achieved by thermally upgrading historic windows and adding secondary glazing (with low emissivity glazing), than with double glazing.⁵

Secondary glazing is more sustainable than replacing the primary windows. It can also be a very cost-effective way of significantly reducing heat loss (by over 50%), whilst enabling the retention of historic fabric, as

⁵ Dr Paul Baker, *Thermal Performance of Traditional Windows*, Glasgow Caledonian University and Historic Scotland, 2008

well as improving a window's acoustic performance

It is important to ensure that in designing the secondary glazing that the bars align with those of the original windows to prevent to prevent any visual harm. Secondary glazing is usually designed with a minimum of glazing bars to avoid this issue. They tend to be painted aluminium frames since this enables them to be of very slim profile.

Thermal performance

Research has shown that heat loss can be reduced by over 60% by using secondary glazing with a low emissivity (Low E) hard coating facing the outside. When used with other methods like blinds or shutters, can reduce heat loss by more than 75%.⁶

Noise reduction

For properties located in areas where heavy traffic is experienced, or other noise pollution, a window's acoustic performance will be an important consideration. Sound is transmitted by direct vibration of the glass and through poor seals. Secondary glazing can help to combat this by providing larger air gaps often than a double-glazed unit. However, it is worth noting that if the primary window is too well sealed, there is the potential to trap condensation between the units. See **Draughtproofing** above, and **Ventilation** below.

Finding the right product

In terms of reducing the visual impact of secondary glazing, it is usually appropriate to install a slim product, which sits as close as possible to the original window. It is important that the system used is compatible with the original window details and does not impede their operation. Where there are working shutters, a solution which avoids

causing a conflict with these should also be sought.

Some manufacturers produce a slim vertical sliding aluminium sash (which can be powder coated in any RAL colour) which can be installed on the staffing bead of the existing sash. Not only does this offer a visually discreet solution but it enables those windows with internal shutter boxes to remain operational.



Figure 2: Vertical sliding sash secondary glazing system which enables the shutters to remain operational (credit: Storm Windows Limited, <https://www.stormwindows.co.uk/>)

Slim double glazing

In some circumstances, **where the original or historic glazing no longer survives**, it may be acceptable to install slimline double glazing within the existing rebates, provided there is capacity, and the frame is strong enough to carry the additional weight (see Appendix A – *Georgian Double Glazed – Slim* and *Victorian Double Glazed – Slim*). Bigger sash weights are also likely to be required but the sash box would need to be big enough to

⁶ <https://historicengland.org.uk/images-books/publications/eehb-secondary-glazing-windows/heag085-secondary-glazing/>

accommodate the increased weight. It is possible too that cast iron weights may need to be replaced with lead.

Slim double glazing tends to be defined as units with a thickness of 14mm or less. They can also combine mouth-blown cylinder glass and can have a traditional putty appearance. Timber beads should not be used to secure the glazing, as this is not a traditional detail and sometimes results in square rebates and shadow gaps, which are not considered appropriate.

The colour of the edge seals must be carefully considered. Black is not considered to be appropriate for white or off-white windows, as it is too intrusive. White seals mean that the sections look too heavy. However, light grey simply looks like a shadow, so is preferable. However, for windows to be painted in dark shade, then black may be preferable.

Unfortunately, linseed oil putty is incompatible with double glazed unit seals and can cause the seal to fail should they come into contact. It is possible to use a proprietary polymer-based putty to seal the unit, and then use linseed oil putty over the top once it has been left to mature. However, it is understood that linseed oil is not necessarily compatible with modern water-based paint finishes anyway. Therefore, an acceptable alternative would be a proprietary synthetic putty which is applied like traditional linseed oil putty, such as Butyl putty.

Slim cavity evacuated glass (e.g. Pilkington's *Spacia* range) is a high performing lighter weight alternative to the standard slim profile double glazing. However, each vacuum unit has a sealing cap which could be considered a

visual intrusion which would need to be weighed against its other benefits.

Replacement windows

There may be instances where replacement windows are required. In situations where the original or historic windows are deemed to be beyond repair, then they should usually be replaced on a like-for-like basis in listed buildings, in particular. In this situation, double glazing is unlikely to be permitted, and secondary glazing should be considered for increased thermal performance.

All efforts should also be made to re-use any surviving original glazing.

Slim double glazing

There may be instances where the historic windows have previously been replaced, perhaps using a pattern or materials which are considered unsympathetic. In these instances, it is possible that a timber double glazed window, reinstating the historic fenestration pattern, might be an acceptable solution. Surviving historic windows on neighbouring properties, historic photos or building plans can provide evidence of how the windows looked originally or historically.⁷

In most circumstances, slim double-glazed units should be used, and this will enable through glazing bars to be used, where the windows have multiple panes (see above and Appendix A). Glazing bar profiles should typically be less than 22mm wide.

However, this may not always be possible in a listed building, for example where the glazing bars need to be especially slender. In this instance, single glazing may be the solution, with secondary glazing.

⁷ Historic images of the district can be viewed on the Lancashire County Council's Red Rose Collections: [Red Rose Collections from Lancashire County Council](#) For historic photographs and images of building plans from Lancashire Archives

from the Mill Race area of Lancaster, see the Mill Race Archive Interactive Map here: <https://www.lancaster.gov.uk/millracearchiveinfo>



Figure 3: Newly installed slim double glazed Accoya timber sashes with through glazing bars. These replaced white uPVC casements in a non-designated heritage asset.



Figure 4: Replacement Accoya double glazed sash windows at Stonewell, Lancaster. Due to its location at a busy junction, a higher acoustic performance was required, necessitating the use of plant-on glazing bars.

Double glazing in non-listed buildings

In instances where the historic windows no longer survive, and there is a requirement for greater acoustic performance in one-over-one windows, or 'two-over-two', then it may be possible to achieve a greater air gap (see Appendix A – Victorian DG Standard). Acoustic laminated glass may also be required, such as Pilkington Optiphon.

However, in the case of a two-over-two sash windows, it would be necessary to use an internal spacer bar, with a plant-on glazing bars to both sides of the unit, with an internal spacer bar to give the appearance of separate panes. This would enable a slender glazing bar to be used, matching the profile of what was there originally. A durable timber, such as Accoya, should be used in these circumstances. The alternative, using two deep sealed units within each sash would necessitate the use of overly heavy glazing bars to protect the edge seals, which would not be appropriate. A glazing bar which is wider than 22mm is unlikely to be acceptable.

The edges should be sealed using a synthetic putty finish, not timber beads (see above).

For fenestration patterns which involve multiple panes, such as six-over-six windows, we would discourage the use of internal spacers and plant-on bars. They tend to be less convincing, especially when the glazing bars are not securely fixed and drop off! However, there have been successful examples where the whole glazing bar system has been manufactured as one piece. Whilst this is still fixed externally to the glass, it is likely to have greater integrity and is less likely to result in in glazing bars dropping off in high winds, for example. Again, internal spacer bars would also need to be used, to give the impression of individual panes.

Alternatively, consideration could be given either to the use of single glazed windows alongside secondary glazing, which is likely to prove the most effective thermally as well as good acoustic performance.

Please note that replacement windows to listed building will require listed building consent. In unlisted buildings within a conservation area, planning permission will be required where the new windows would represent a change in material and/or design.

Ventilation

Whilst improved insulation and draught exclusion are the primary aim in upgrading windows, it is important to remember that ventilation is still very important for the prevention of condensation and the air quality within the building generally.

Trickle vents are used in modern windows to address this issue. However, surface-applied trickle vents are visually obtrusive on any style of window (Figure 5), but especially sash windows.

It is possible to successfully incorporate a *concealed* trickle vent system into a new timber sash window. This works by enabling air to flow through the sash box (see Figure 7). This does mean a chamfer to the top rail of the top sash.

One of the many ways in which a sash window can provide ventilation is simply through releasing a screwed Brighton fastener (Figure 6). This is considered by some to provide the same level of ventilation as a trickle vent (see Ironmongery below).



Figure 5: Timber sash window with surface mounted trickle vent



Figure 6: A Brighton fastener which can be unscrewed or tightened to control the ventilation, as well as for security and safety purposes

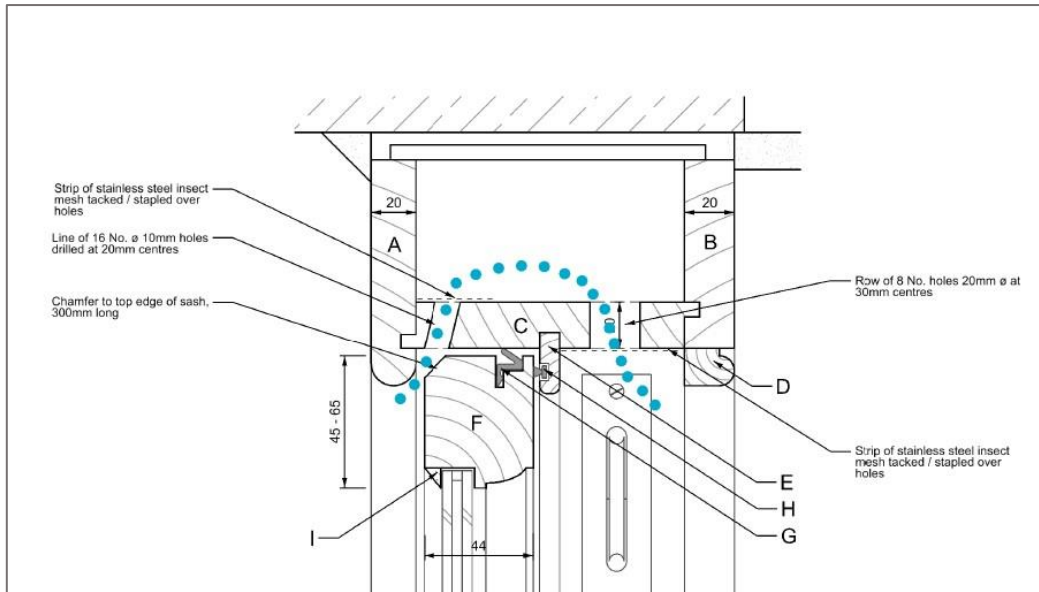

Figure 7: Sash window head section with concealed trickle vent (see Appendix A for the full trickle vent drawings)

Materials

Plastic (uPVC) windows are not considered appropriate for use in historic buildings. They are unable to match the sections and proportions of historic joinery, making them appear much heavier, and are instantly recognisable as non-traditional windows. Mitred joints are also a clear indicator of a non-traditional material. They lack the elegance and patina of painted timber windows. They often involve the glazing bars sandwiched between the panes of glass.

Repairs to uPVC windows are problematic and they are made from non-renewable petroleum products, generating pollution during their manufacture and disposal.⁸ This makes them an unsustainable option compared to timber.



Figure 8: A rather unconvincing sash window where the sandwiched glazing bars have failed.

⁸ *Warmer Bath: A Guide to improving the energy efficiency of traditional homes in the city of Bath*, Bath Preservation Trust and the Centre of Sustainable Energy, 2011 ([https://www.bath-](https://www.bath-preservation-trust.org.uk/wp-content/uploads/2022/04/Warmer-Bath.pdf)

[preservation-trust.org.uk/wp-content/uploads/2022/04/Warmer-Bath.pdf](https://www.bath-preservation-trust.org.uk/wp-content/uploads/2022/04/Warmer-Bath.pdf)

New windows should be manufactured from solid hardwoods, such as European Oak, or from Accoya which is recognised as being highly durable. Softwood for new windows is inadvisable and they are unlikely to have a long lifespan.

Sash horns

Sash horns began to appear as cheaper and stronger plate glass (drawn sheet glass) became available from the 1830s which resulted in larger, uninterrupted panes of glass, reducing the need for glazing bars. However, the increased weight meant that sash horns were required to strengthen the vulnerable joints at either end of the meeting rail. Therefore, they might be expected to be seen on 'one-over-one' or 'two-over-two' sash windows, for example. However, you would not usually expect to see them on multi-paned sashes, though often do on C20 sashes, where they are used for purely aesthetic reasons.

Sash horns should appear as a continuous element of the stile, rather than an add-on. Examples of sash horn profiles can be found in Appendix C.

Glass

It is very important that historic glazing is retained where it survives and that it is treated with special care. Historic glazing was handmade and contains irregularities, giving it character and interest.

You can tell from the type of irregularity in the glass what type it might be. For example, bubbles or 'seeds' tend to be found in **cylinder glass**.

Crown glass, which was used widely during the Georgian period, often has characteristic circular lines, reflecting the way it was made, which involved spinning a balloon shape until it formed a disc.

As mentioned above, **drawn sheet glass** was invented in the 1830s, and enabled larger sheets to be made cheaply and meant that multi-paned sashes generally became a thing of the past from the mid-C19 (though small-paned top sashes are often found in late C19 and early C20 buildings).

During the early C20, machine-drawn cylinder glass was introduced, followed by flat-drawn sheet glass, but it was in 1959 that glass production was revolutionised with the invention of **float glass**. The quality was high and production costs low.⁹

For window repairs, a good alternative to crown glass (which is no longer made) is **Cordele**, also known as P1, which is a mouth-blown restoration glass. This is available from stained glass suppliers and is a better alternative to horticultural glass (also see Tatra Glass: <https://tatraglass.co.uk/heritage-mouth-blown-glass/>).

Heritage Drawn Glass is also available from Tatra Glass, which has an authentic wavy surface. This comes in two thicknesses. However, it can also be paired with a high-thermal and UV filtering glass to provide a laminated glass, the Heritage Drawn ECO Laminated range, as well as used in slimline double-glazed systems with a Low-E glass: <https://tatraglass.co.uk/heritage-drawn-3-3-and-4-5/>

⁹ *Old House Handbook: A Practical Guide to Care and Repair*, Hunt, S., & Suhr, M., SPAB, 2008, p.143.



Figure 9: Characterful historic glazing in an 1870s house. This is likely to be drawn sheet glass.

Paint

When deciding what paint to use, colour is not the only consideration. It is important to carefully select the type of paint and the gloss level. Compatibility with the paint that has been used previously is also important.

Historically, oil paints (linseed oil and lead white) would have been used. Lead paint is still available under licence and, with permission from Historic England, may be used on grade I and II* listed buildings.

The oil paint's glossy finish would tend to dull over time and the linseed content would cause it to yellow. Therefore, brilliant white full gloss would not be a sympathetic approach.¹⁰

If the intention is to have very light windows, then an off-white in a satin finish or a semi-

gloss would be preferable. Greyish whites can help give a more authentic appearance to historic windows.

However, there has been a move towards the use of colour for windows in recent years. This does reflect the wider use of darker colours that could be seen on sash windows from the later 1700s and throughout the 1800s. The colours used initially were dark greys and browns, with greens sometimes used for Regency joinery.¹¹

During the Victorian period, however, stronger colours were often used, and olive and purple-brown were popular colours for exterior joinery. Russet, a red-brown, is another colour often found.¹²

In terms of paint choices, exterior eggshell paint tends to have a low sheen (15-20%) and is usually water-based. There are some oil-based paints which have a low sheen, such as Little Greene's *Tom's Oil Eggshell*. Their Traditional Oil Gloss has a 90% sheen, and their Intelligent Gloss, which is water-based, has an 80% sheen.¹³

An alternative to lead paint would be to use a traditional linseed oil paint, which today uses zinc and titanium white instead of lead. This is also an environmentally friendly option. See Broun's & Co.¹⁴

Ironmongery

Early sash windows had brass or timber pulley wheels, with lead weights, which later became cast iron.

Sash window ironmongery would also include a form of fastener to secure the sashes and sometimes sash lifts. These were wrought iron initially, but the use of brass or bronze became more widespread during the late C18

¹⁰ *The Victorian Society Book of the Victorian House*, Wedd, K., 2002, p. 225

¹¹ *The Georgian Group Book of the Georgian House*, Parissien, S., 2001, pp. 99-100

¹² *The Victorian Society Book of the Victorian House*, Wedd, K., 2002, p. 224

¹³ Little Greene:

<https://www.littlegreene.com/paint/finishes/exterior-paint-finishes>

¹⁴ Broun's & Co: <https://linseedpaint.com/>

in more prestigious properties. Nevertheless, traditional iron hinges and fasteners continued to be used in humbler buildings throughout the C19. However, by the mid-C19, these fittings were more likely to be cast iron.



Figure 10: A brass reeded sash bar handle



Figure 11: an over-painted brass sash ring lift

In 1930, the spiral sash balance was patented, which removed the need for sash cords. This involves a spring housed in grooves in the side of the sashes. These are sometimes used in modern sashes, but for listed buildings, traditional weighted sash cords are generally expected to be used.

Original or historic ironmongery should be retained and restored (it has often been over-painted), and it can be possible to source replica items for those that are missing or damaged.

Brass details are commonly used today, and there are a variety of fasteners available, including Brighton Fasteners, which are a screw-type, as well as fitch fasteners which are available with a locking pin. Other security measures include sash screws and restrictors. Restrictors, called 'sash stops', can also be used to help prevent sashes from opening fully or to prevent accidents and falls where a cill is low. In some cases, this will be a technical requirement. These are available as brass fittings.



Figure 12: Fitch fastener with locking pin (to the front of the lever)



Figure 13: Brass restrictor. This can be unscrewed and moved into the alternative position with a key.

A detail commonly found in Scotland involves the use of Simplex hinges which enable the bottom sash to open inwards, as a casement window, which makes it easier to clean and repair, where access might be an issue.

However, the other elements required to enable its opening in this way include rod screws, cord grips and cord clutches. These are able to be retrofitted to existing sash windows.



Figure 14: A Simplex hinge, with the locating screw fixed into the bottom sash, brass over painted

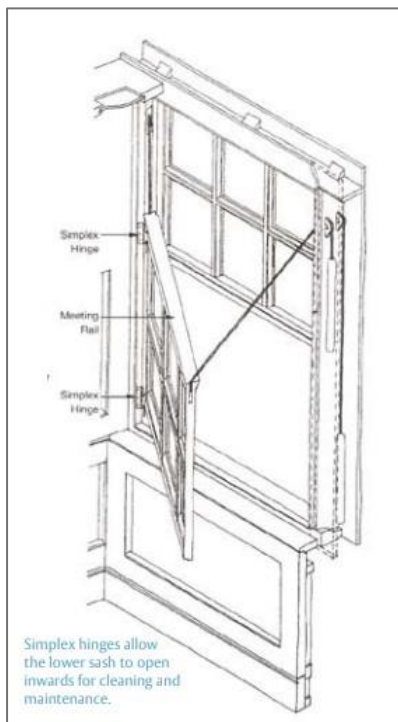

Figure 15: Simplex hinge in action (credit: Historic Environment Scotland, *Sash & Case Windows: A Short Guide for Homeowners*, 2008)

Burnt sand mastic pointing

Traditional burnt sand mastic has been used for over 200 years to seal the joints between timber window (and door) frames and masonry. It contains burnt sand and boiled linseed oil. It hardens slowly and but remains flexible whilst adhering well to the surface.¹⁵

The colour should be chosen to match the surrounding masonry or mortar, in the case of bricks, as closely as possible. Usually, a buff stone colour works best.

Mastic is not intended to be over-painted.



Figure 16: Burnt sand mastic pointing to seal around the timber frame in a buff stone colour.

¹⁵ Traditional burnt sand mastic pointing, Scottish Lime Centre Trust. Sourced: [https://fifehistoricbuildings.org.uk/wp-](https://fifehistoricbuildings.org.uk/wp-content/uploads/2019/09/Appendix-N-Traditional-burnt-sand-mastic-pointing.pdf)

[content/uploads/2019/09/Appendix-N-Traditional-burnt-sand-mastic-pointing.pdf](https://fifehistoricbuildings.org.uk/wp-content/uploads/2019/09/Appendix-N-Traditional-burnt-sand-mastic-pointing.pdf)

Appendix A: Sash window sections:

Georgian Single Glazed	(pp.19-25)
Georgian Double Glazed – Slim	(pp.26-32)
Victorian Single Glazed	(pp.33-39)
Victorian Double Glazed – Slim	(pp.40-46)
Victorian Double Glazed – Standard	(pp.47-53)
<i>(for 'one-over-one' and 'two-over-two' sashes in non-listed buildings where greater acoustic performance is required)</i>	

Please note: these window drawings are provided for information and guidance purposes only. The council accepts no liability for any loss, damage or inconvenience caused as a result of reliance on this information.

LANCASTER CITY COUNCIL

Promoting City, Coast & Countryside

These drawings are
intended for guidance only

- A OUTER LINING
- B INNER LINING
- C SOFFIT LINING
- D STAFF BEAD
- E PARTING BEAD
- F TOP RAIL
- G AQUAMAC 21 DRAUGHT
SEAL OR EQUIVALENT
- H DRAUGHT STRIP
- I GLAZING PUTTY
- J MEETING RAILS
- K TIMBER CILL (HARD
WOOD OR ACCOYA)
- L STONE CILL
- M BOTTOM RAIL
- N WINDOW BOARD
- O GLAZING BAR
- P SASH STILE
- Q PULLEY STILE
- R SASH WEIGHTS (CAST
IRON OR LEAD)
- S SEALANT POINTING

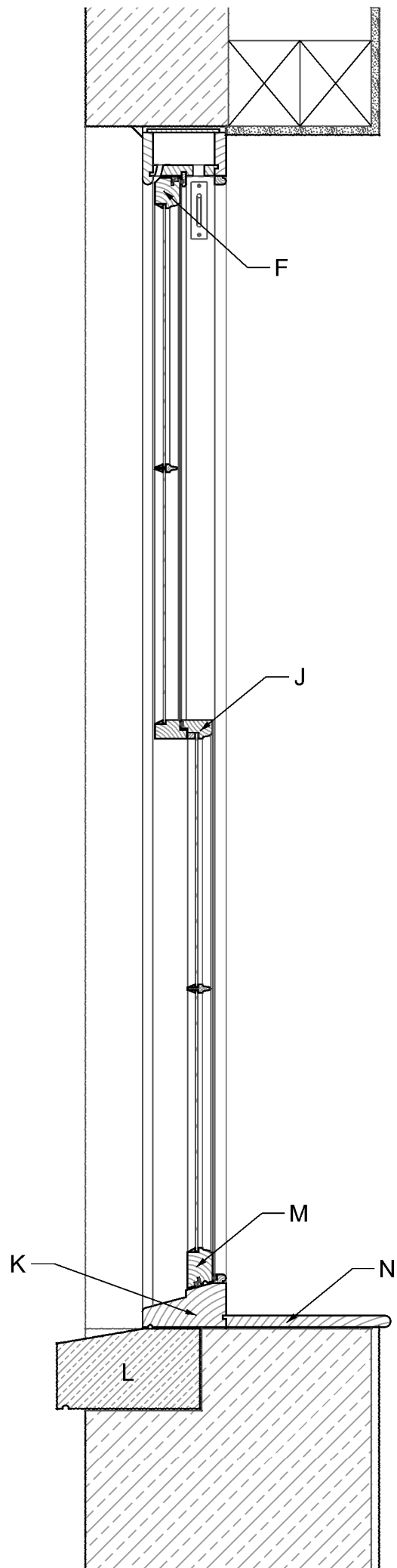

Sheet: G(A)-SG-03

Style: GEORGIAN SASH WINDOW

Glazing: Single Glazed

Drawing: Full Section

Scale: 1:10 @ A4

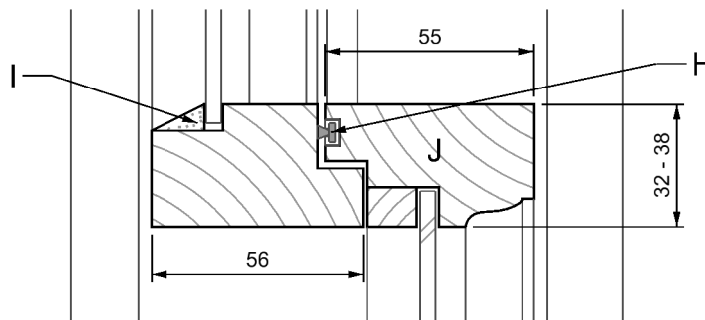
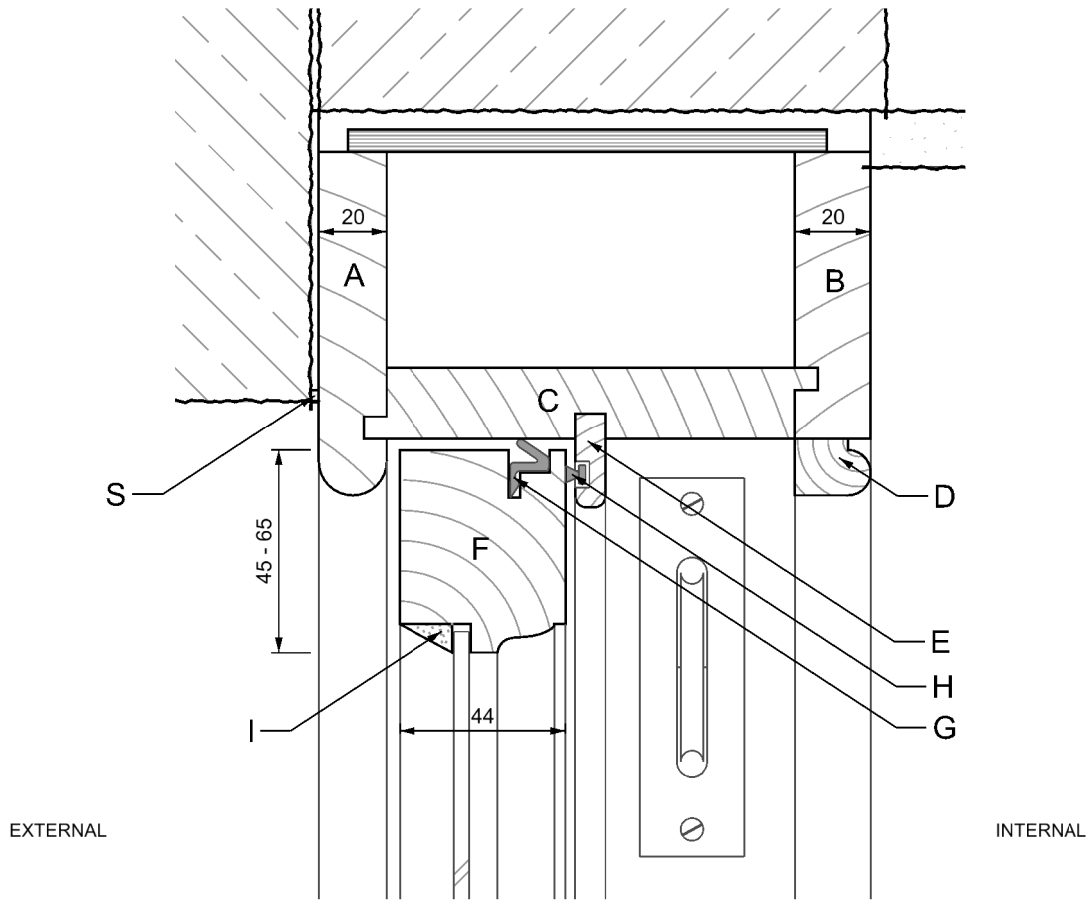

These drawings are intended for guidance only

LANCASTER CITY COUNCIL
Promoting City, Coast & Countryside

Sheet: G(A)-SG-04
Style: GEORGIAN SASH WINDOW
Glazing: Single Glazed
Drawing: Head and Meeting Rail
Scale: 1:2 @ A4

- | | | | |
|---|---------------------------------------|---|-----------------------------------|
| A | OUTER LINING | K | TIMBER CILL (HARD WOOD OR ACCOYA) |
| B | INNER LINING | L | STONE CILL |
| C | SOFFIT LINING | M | BOTTOM RAIL |
| D | STAFF BEAD | N | WINDOW BOARD |
| E | PARTING BEAD | O | GLAZING BAR |
| F | TOP RAIL | P | SASH STILE |
| G | AQUAMAC 21 DRAUGHT SEAL OR EQUIVALENT | Q | PULLEY STILE |
| H | DRAUGHT STRIP | R | SASH WEIGHTS (CAST IRON OR LEAD) |
| I | GLAZING PUTTY | S | SEALANT POINTING |
| J | MEETING RAILS | | |

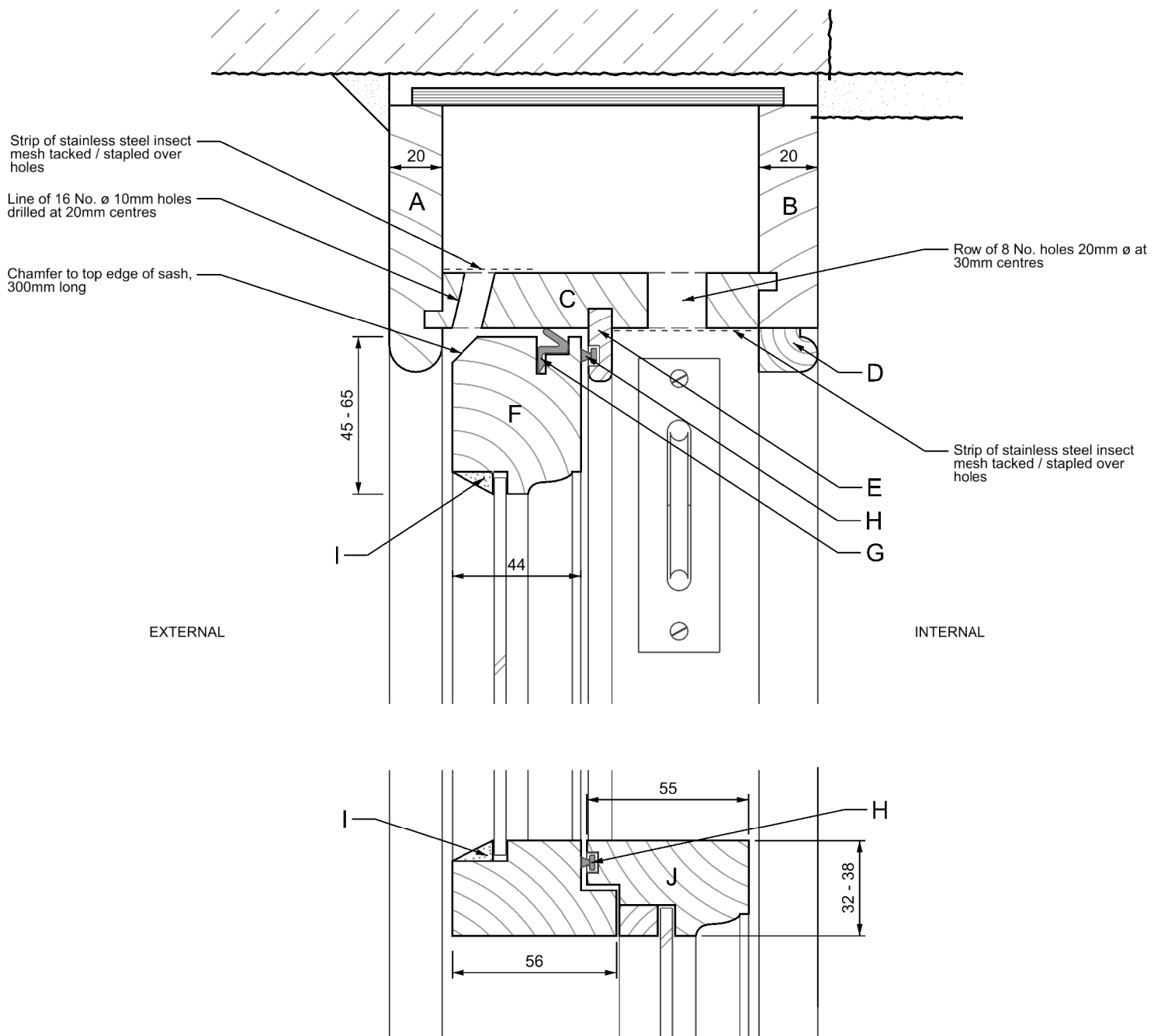

These drawings are intended for guidance only

LANCASTER
CITY COUNCIL

Promoting City, Coast & Countryside

Sheet: G(A)-SG-05

Style: GEORGIAN SASH WINDOW
Glazing: Single Glazed
Drawing: Head with concealed trickle vent and Meeting Rail

Scale: 1:2 @ A4

A OUTER LINING
B INNER LINING
C SOFFIT LINING
D STAFF BEAD
E PARTING BEAD
F TOP RAIL
G AQUAMAC 21 DRAUGHT SEAL OR EQUIVALENT
H DRAUGHT STRIP
I GLAZING PUTTY
J MEETING RAILS

K TIMBER CILL (HARD WOOD OR ACCOYA)
L STONE CILL
M BOTTOM RAIL
N WINDOW BOARD
O GLAZING BAR
P SASH STILE
Q PULLEY STILE
R SASH WEIGHTS (CAST IRON OR LEAD)
S SEALANT POINTING

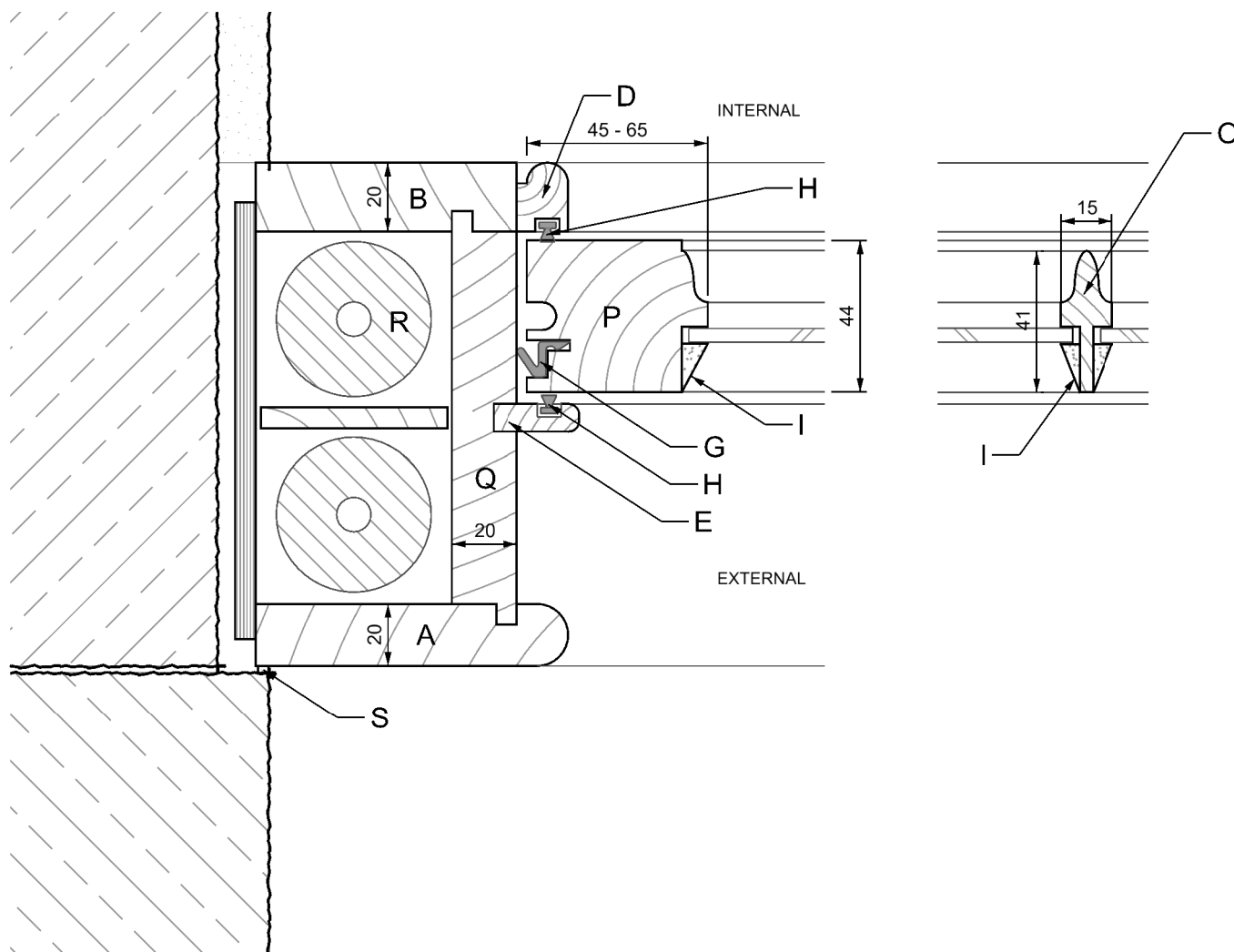

These drawings are intended for guidance only



Sheet: G(A)-SG-06
 Style: GEORGIAN SASH WINDOW
 Glazing: Single Glazed
 Drawing: Jamb and Glazing Bar
 Scale: 1:2 @ A4

- | | | | |
|---|---------------------------------------|---|-----------------------------------|
| A | OUTER LINING | K | TIMBER CILL (HARD WOOD OR ACCOYA) |
| B | INNER LINING | L | STONE CILL |
| C | SOFFIT LINING | M | BOTTOM RAIL |
| D | STAFF BEAD | N | WINDOW BOARD |
| E | PARTING BEAD | O | GLAZING BAR |
| F | TOP RAIL | P | SASH STILE |
| G | AQUAMAC 21 DRAUGHT SEAL OR EQUIVALENT | Q | PULLEY STILE |
| H | DRAUGHT STRIP | R | SASH WEIGHTS (CAST IRON OR LEAD) |
| I | GLAZING PUTTY | S | SEALANT POINTING |
| J | MEETING RAILS | | |

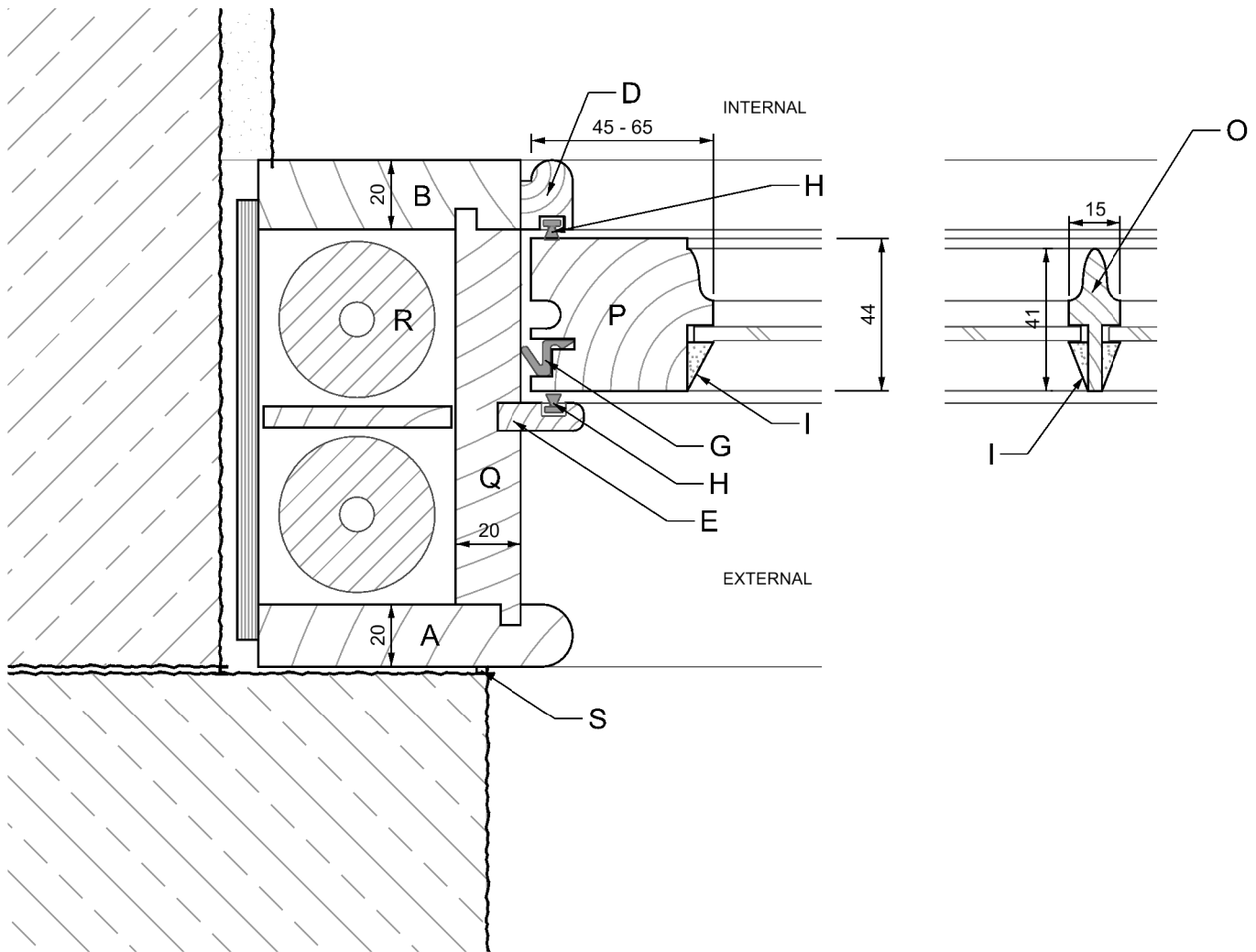

These drawings are intended for guidance only

Sheet: G(A)-SG-07
Style: GEORGIAN SASH WINDOW
Glazing: Single Glazed
Drawing: Jamb Rebated and Glazing Bar
Scale: 1:2 @ A4

- | | | | |
|---|---------------------------------------|---|-----------------------------------|
| A | OUTER LINING | K | TIMBER CILL (HARD WOOD OR ACCOYA) |
| B | INNER LINING | L | STONE CILL |
| C | SOFFIT LINING | M | BOTTOM RAIL |
| D | STAFF BEAD | N | WINDOW BOARD |
| E | PARTING BEAD | O | GLAZING BAR |
| F | TOP RAIL | P | SASH STILE |
| G | AQUAMAC 21 DRAUGHT SEAL OR EQUIVALENT | Q | PULLEY STILE |
| H | DRAUGHT STRIP | R | SASH WEIGHTS (CAST IRON OR LEAD) |
| I | GLAZING PUTTY | S | SEALANT POINTING |
| J | MEETING RAILS | | |

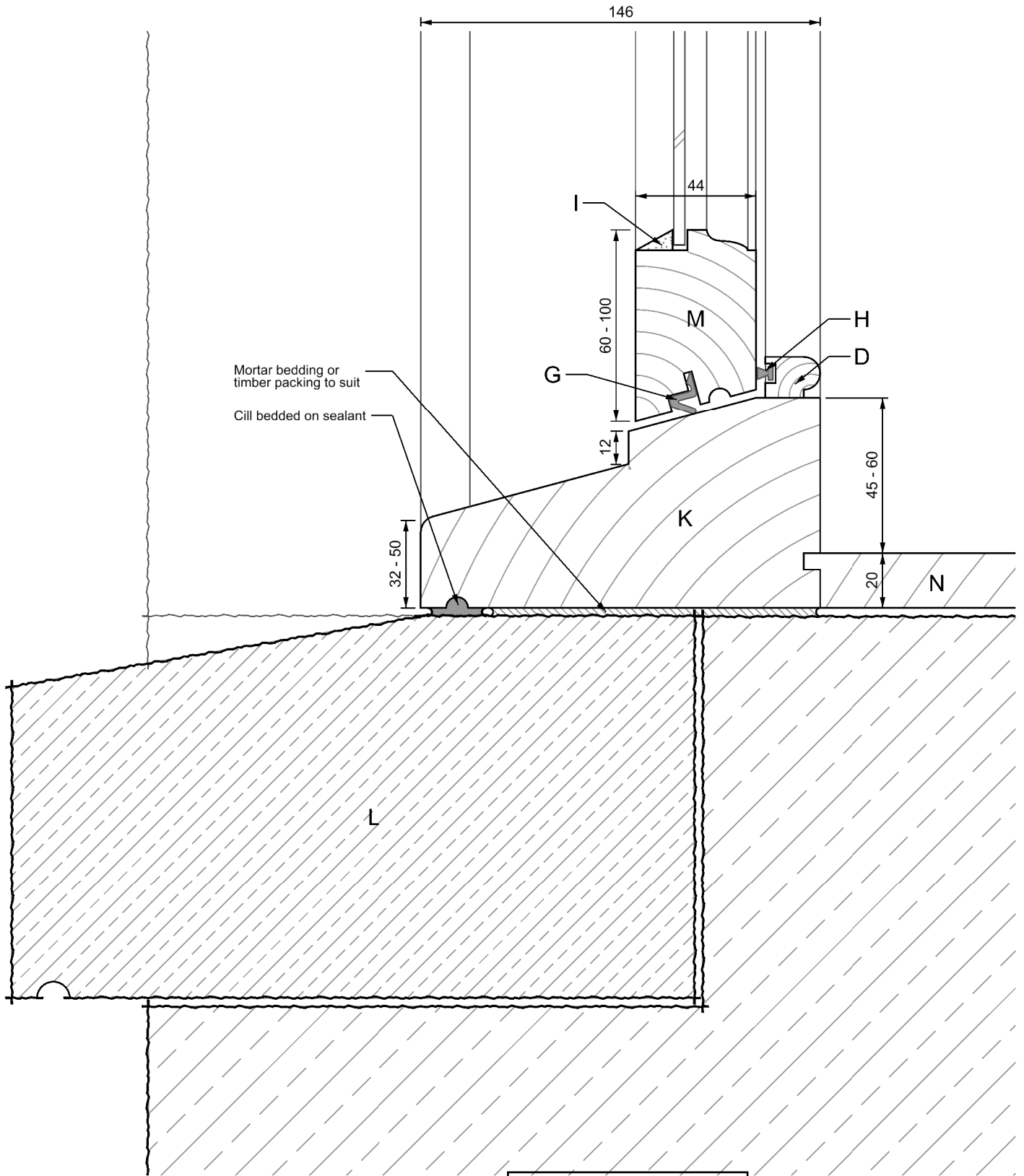

These drawings are intended for guidance only

A	OUTER LINING	K	TIMBER CILL (HARD WOOD OR ACCOYA)
B	INNER LINING	L	STONE CILL
C	SOFFIT LINING	M	BOTTOM RAIL
D	STAFF BEAD	N	WINDOW BOARD
E	PARTING BEAD	O	GLAZING BAR
F	TOP RAIL	P	SASH STILE
G	AQUAMAC 21 DRAUGHT SEAL OR EQUIVALENT	Q	PULLEY STILE
H	DRAUGHT STRIP	R	SASH WEIGHTS (CAST IRON OR LEAD)
I	GLAZING PUTTY	S	SEALANT POINTING
J	MEETING RAILS		

Sheet: G(A)-SG-01

Style: GEORGIAN SASH WINDOW
 Glazing: Single Glazed
 Drawing: Cill

Scale: 1:2 @ A4

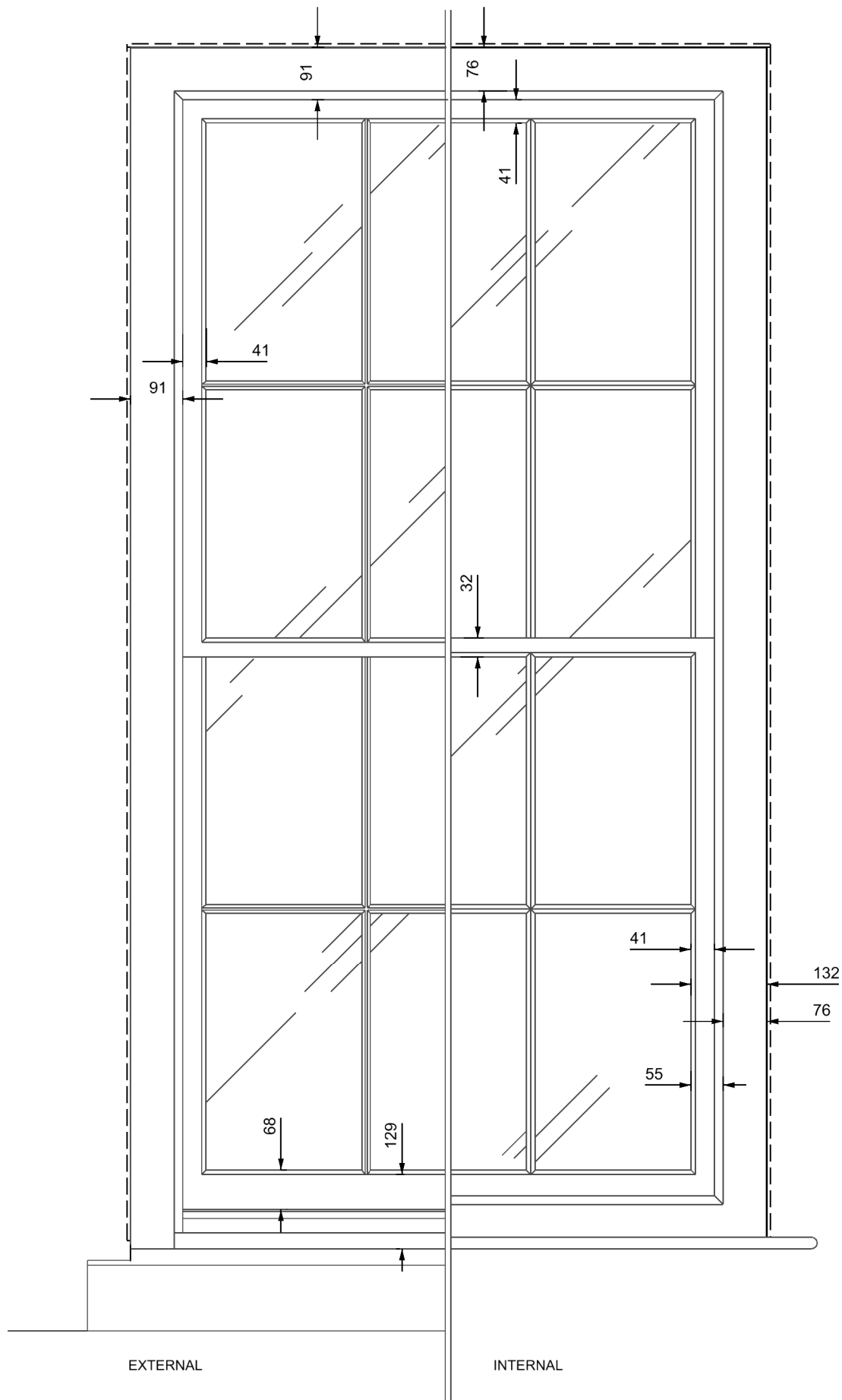

Sheet: G(A)-DG-Slim-02
Style: GEORGIAN SASH WINDOW
Glazing: Double Glazed (Slim 4/4/4)
Drawing: Internal and External Elevation
Scale: 1:10 @ A4

LANCASTER
CITY COUNCIL
Promoting City, Coast & Countryside

These drawings are intended for guidance only

LANCASTER CITY COUNCIL

Promoting City, Coast & Countryside

These drawings are intended for guidance only

- A OUTER LINING
- B INNER LINING
- C SOFFIT LINING
- D STAFF BEAD
- E PARTING BEAD
- F TOP RAIL
- G AQUAMAC 21 DRAUGHT SEAL OR EQUIVALENT
- H DRAUGHT STRIP
- I GLAZING PUTTY
- J MEETING RAILS
- K TIMBER CILL (HARD WOOD OR ACCOYA)
- L STONE CILL
- M BOTTOM RAIL
- N WINDOW BOARD
- O GLAZING BAR
- P SASH STILE
- Q PULLEY STILE
- R SASH WEIGHTS (CAST IRON OR LEAD)
- S SEALANT POINTING

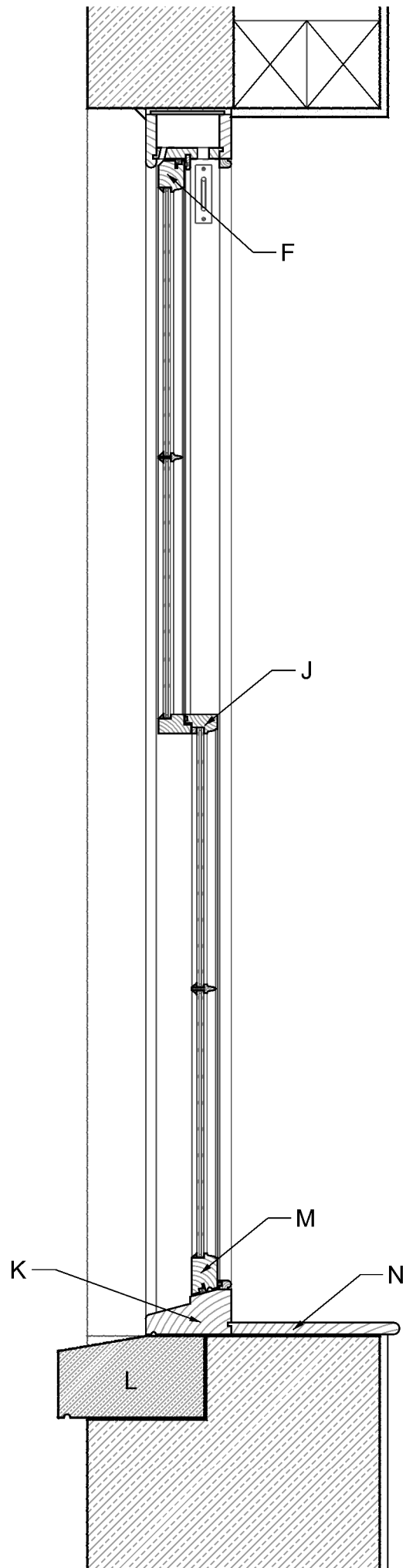

Sheet: G(A)-DG-Slim-03

Style: GEORGIAN SASH WINDOW
 Glazing: Double Glazed (Slim 4/4/4)
 Drawing: Full Section

Scale: 1:10 @ A4

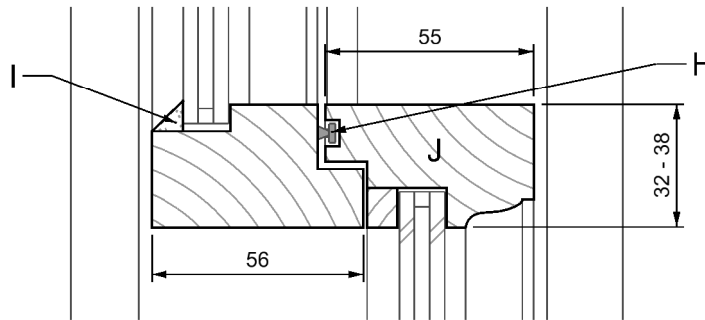
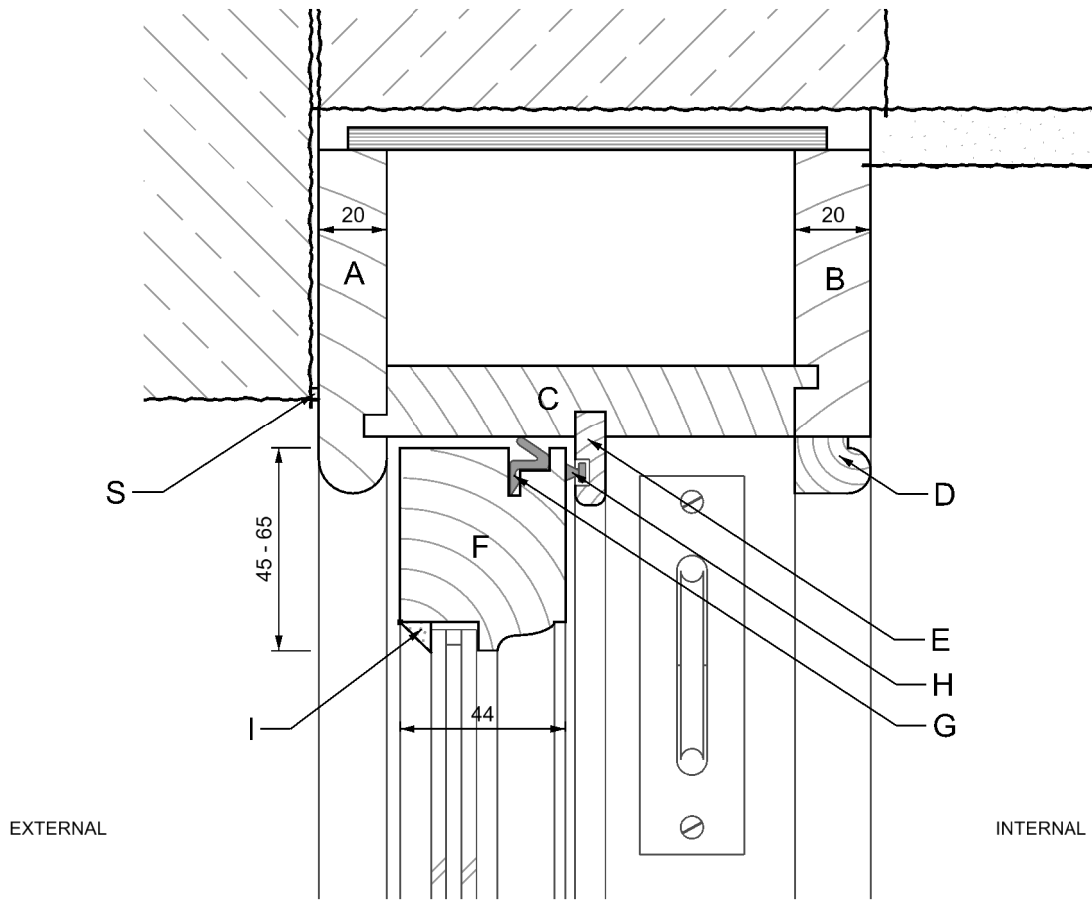

LANCASTER
CITY COUNCIL

Promoting City, Coast & Countryside

These drawings are intended for guidance only

Sheet: G(A)-DG-Slim-04
Style: GEORGIAN SASH WINDOW
Glazing: Double Glazed (Slim 4/4/4)
Drawing: Head and Meeting Rail
Scale: 1:2 @ A4

A OUTER LINING
B INNER LINING
C SOFFIT LINING
D STAFF BEAD
E PARTING BEAD
F TOP RAIL
G AQUAMAC 21 DRAUGHT SEAL OR EQUIVALENT
H DRAUGHT STRIP
I GLAZING PUTTY
J MEETING RAILS

K TIMBER CILL (HARD WOOD OR ACCOYA)
L STONE CILL
M BOTTOM RAIL
N WINDOW BOARD
O GLAZING BAR
P SASH STILE
Q PULLEY STILE
R SASH WEIGHTS (CAST IRON OR LEAD)
S SEALANT POINTING

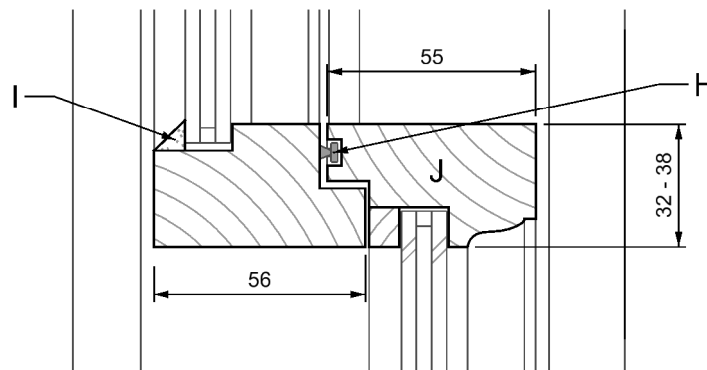
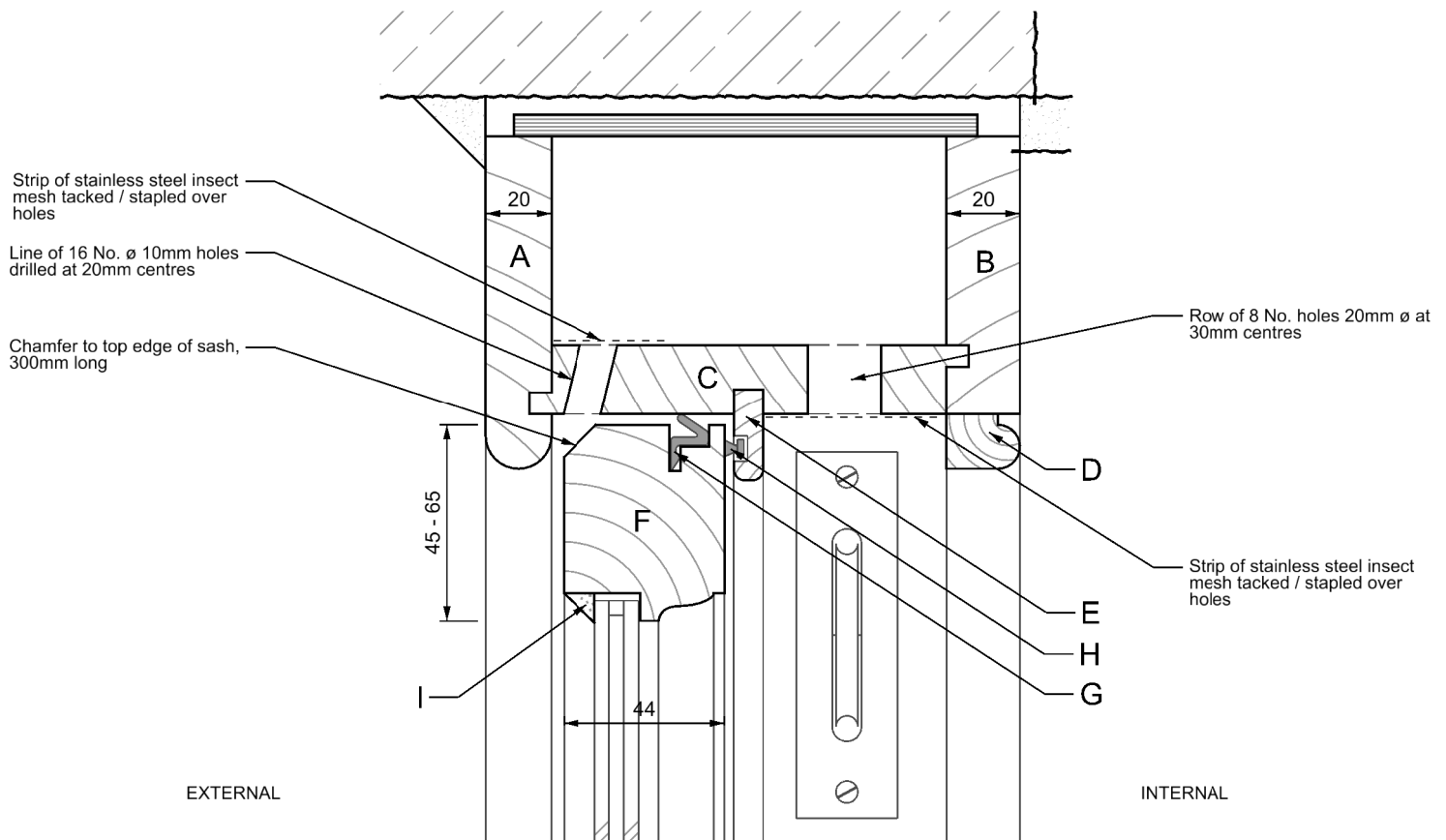

**LANCASTER
CITY COUNCIL**

Promoting City, Coast & Countryside

These drawings are intended for guidance only

Sheet: G(A)-DG-Slim-05

Style: GEORGIAN SASH WINDOW

Glazing: Double Glazed (Slim 4/4/4)

Drawing: Head with concealed trickle vent and Meeting Rail

Scale: 1:2 @ A4

A OUTER LINING
B INNER LINING
C SOFFIT LINING
D STAFF BEAD
E PARTING BEAD
F TOP RAIL
G AQUAMAC 21 DRAUGHT SEAL OR EQUIVALENT
H DRAUGHT STRIP
I GLAZING PUTTY
J MEETING RAILS

K TIMBER CILL (HARD WOOD OR ACCOYA)
L STONE CILL
M BOTTOM RAIL
N WINDOW BOARD
O GLAZING BAR
P SASH STILE
Q PULLEY STILE
R SASH WEIGHTS (CAST IRON OR LEAD)
S SEALANT POINTING

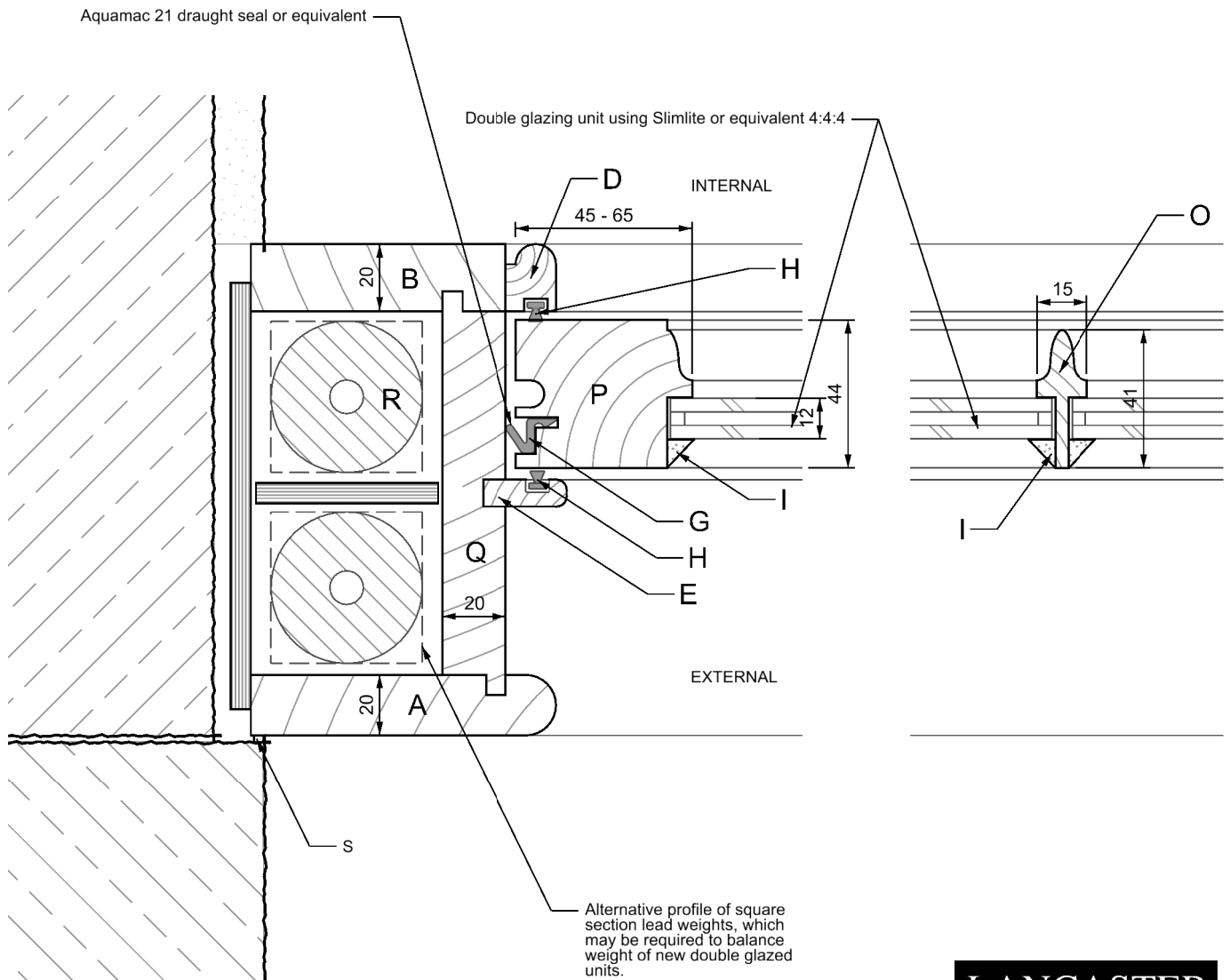

LANCASTER
CITY COUNCIL
Promoting City, Coast & Countryside

These drawings are intended for guidance only

Sheet: G(A)-DG-Slim-06
Style: GEORGIAN SASH WINDOW
Glazing: Double Glazed (Slim 4/4/4)
Drawing: Jamb and Glazing Bar
Scale: 1:2 @ A4

A	OUTER LINING	K	TIMBER CILL (HARD WOOD OR ACCOYA)
B	INNER LINING	L	STONE CILL
C	SOFFIT LINING	M	BOTTOM RAIL
D	STAFF BEAD	N	WINDOW BOARD
E	PARTING BEAD	O	GLAZING BAR
F	TOP RAIL	P	SASH STILE
G	AQUAMAC 21 DRAUGHT SEAL OR EQUIVALENT	Q	PULLEY STILE
H	DRAUGHT STRIP	R	SASH WEIGHTS (CAST IRON OR LEAD)
I	GLAZING PUTTY	S	SEALANT POINTING
J	MEETING RAILS		

NOTES:
Glazing - replacement single glazing typically 4mm thick. Upgrade "slim" double glazing units typically 4/4/4mm if rebates can be adapted to suit.
Putty - for single glazing traditional linseed putty may be used. Double glazed units may require polymer glazing putty according to the d.g. unit manufacturers recommendation.
Timber - for "pieced-in" repairs use tight grained softwood to match existing as closely as possible e.g. redwood, Douglas Fir, free of knots.
Replacement cills or complete new elements may use a durable hardwood.
Finishes - Traditional linseed oil paint, or a micro-porous paint system.
*Note that heavier d.g. units will require heavier sash weights in cast iron or lead.

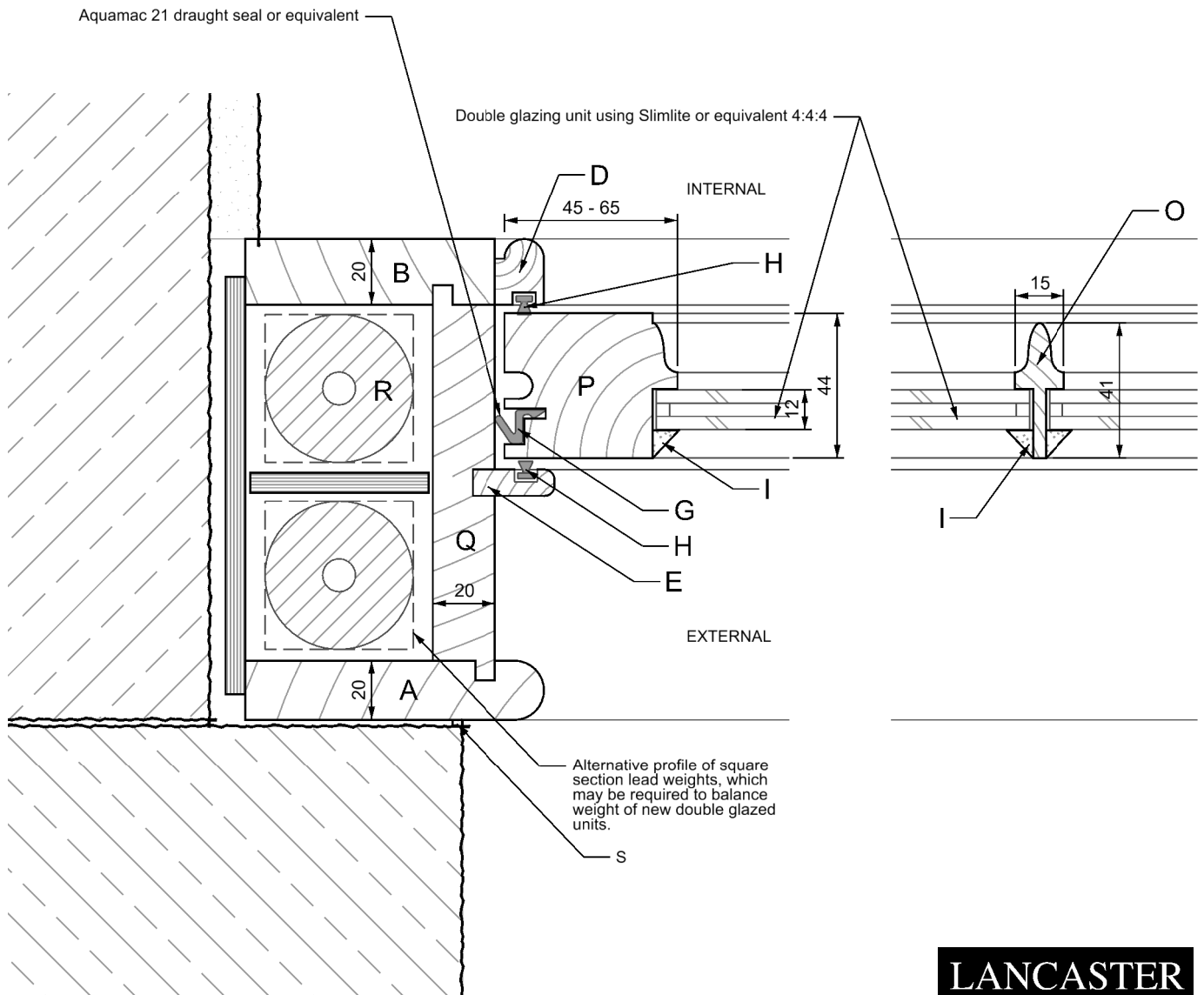

LANCASTER CITY COUNCIL

Promoting City, Coast & Countryside

These drawings are
intended for guidance only

Sheet: G(A)-DG-Slim-07
Style: GEORGIAN SASH WINDOW
Glazing: Double Glazed (Slim 4/4/4)
Drawing: Jamb Rebated and Glazing Bar
Scale: 1:2 @ A4

A	OUTER LINING	K	TIMBER CILL (HARD WOOD OR ACCOYA)
B	INNER LINING	L	STONE CILL
C	SOFFIT LINING	M	BOTTOM RAIL
D	STAFF BEAD	N	WINDOW BOARD
E	PARTING BEAD	O	GLAZING BAR
F	TOP RAIL	P	SASH STILE
G	AQUAMAC 21 DRAUGHT SEAL OR EQUIVALENT	Q	PULLEY STILE
H	DRAUGHT STRIP	R	SASH WEIGHTS (CAST IRON OR LEAD)
I	GLAZING PUTTY	S	SEALANT POINTING
J	MEETING RAILS		

NOTES:

Glazing - replacement single glazing typically 4mm thick. Upgrade "slim" double glazing units typically 4/4/4mm if rebates can be adapted to suit. Putty - for single glazing traditional linseed putty may be used. Double glazed units may require polymer glazing putty according to the d.g. unit manufacturers recommendation.

Timber - for "pieced-in" repairs use tight grained softwood to match existing as closely as possible e.g. redwood, Douglas Fir, free of knots.

Replacement cills or complete new elements may use a durable hardwood.

Finishes - Traditional linseed oil paint, or a micro-porous paint system.

*Note that heavier d.g. units will require heavier sash weights in cast iron or lead.

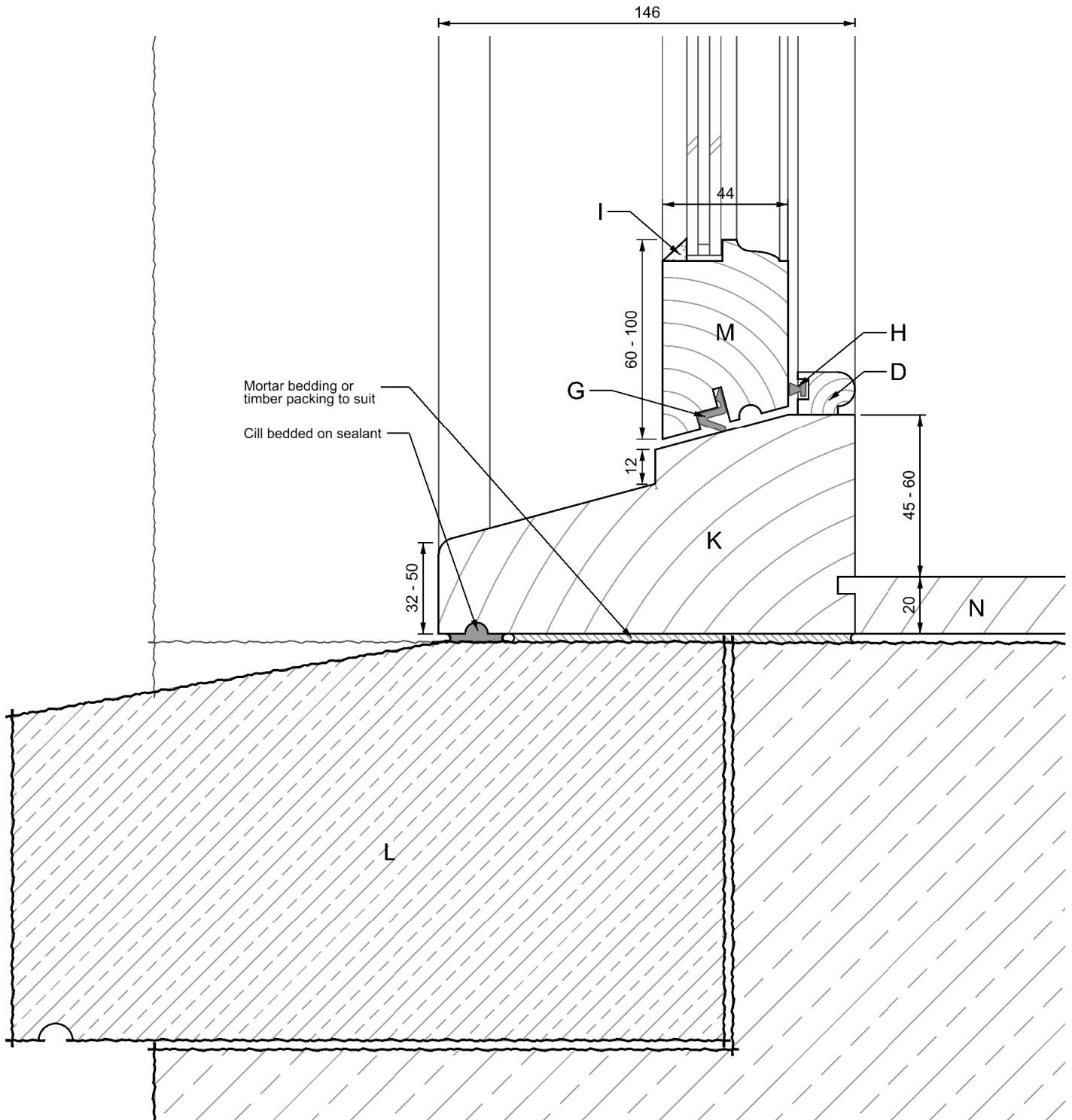

Sheet: G(A)-DG-Slim-01
Style: GEORGIAN SASH WINDOW
Glazing: Double Glazed (Slim 4/4/4)
Drawing: Cill
Scale: 1:2 @ A4

- | | | | |
|---|---------------------------------------|---|-----------------------------------|
| A | OUTER LINING | K | TIMBER CILL (HARD WOOD OR ACCOYA) |
| B | INNER LINING | L | STONE CILL |
| C | SOFFIT LINING | M | BOTTOM RAIL |
| D | STAFF BEAD | N | WINDOW BOARD |
| E | PARTING BEAD | O | GLAZING BAR |
| F | TOP RAIL | P | SASH STILE |
| G | AQUAMAC 21 DRAUGHT SEAL OR EQUIVALENT | Q | PULLEY STILE |
| H | DRAUGHT STRIP | R | SASH WEIGHTS (CAST IRON OR LEAD) |
| I | GLAZING PUTTY | S | SEALANT POINTING |
| J | MEETING RAILS | | |

LANCASTER CITY COUNCIL

Promoting City, Coast & Countryside

These drawings are intended for guidance only

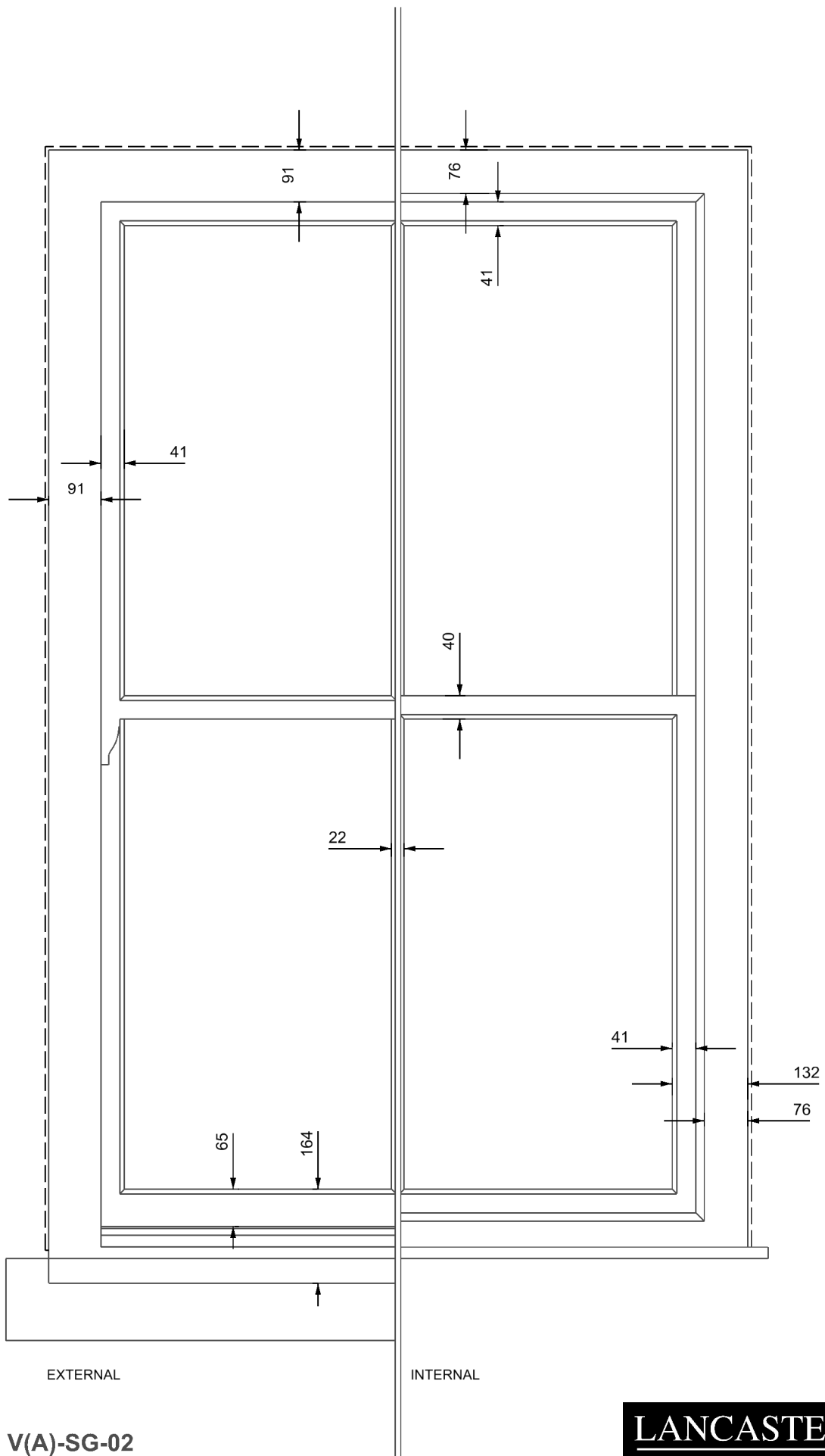

Sheet: V(A)-SG-02
Style: VICTORIAN SASH WINDOW
Glazing: Single Glazed
Drawing: Internal and External Elevation
Scale: 1:10 @ A4



These drawings are intended for guidance only

These drawings are intended for guidance only

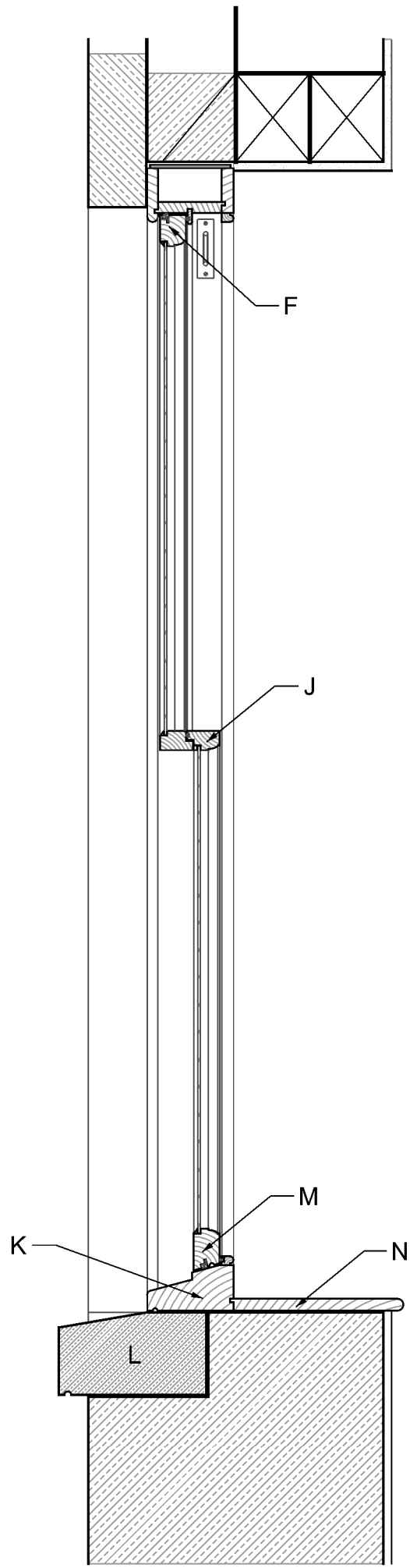

- A OUTER LINING
- B INNER LINING
- C SOFFIT LINING
- D STAFF BEAD
- E PARTING BEAD
- F TOP RAIL
- G AQUAMAC 21 DRAUGHT SEAL OR EQUIVALENT
- H DRAUGHT STRIP
- I GLAZING PUTTY
- J MEETING RAILS
- K TIMBER CILL (HARD WOOD OR ACCOYA)
- L STONE CILL
- M BOTTOM RAIL
- N WINDOW BOARD
- O GLAZING BAR
- P SASH STILE
- Q PULLEY STILE
- R SASH WEIGHTS (CAST IRON OR LEAD)
- S SEALANT POINTING

Sheet: V(A)-SG-03
Style: VICTORIAN SASH WINDOW
Glazing: Single Glazed
Drawing: Full Section
Scale: 1:10 @ A4

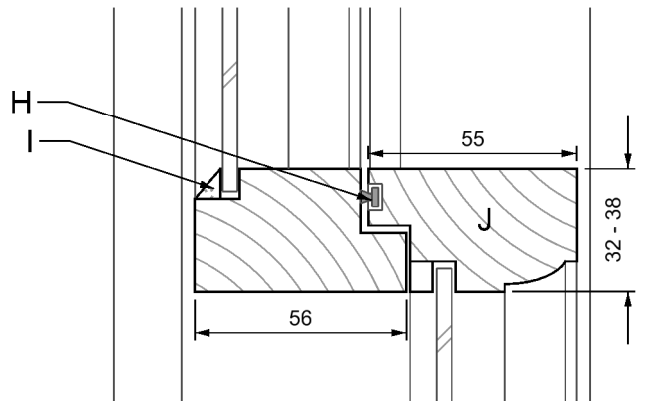
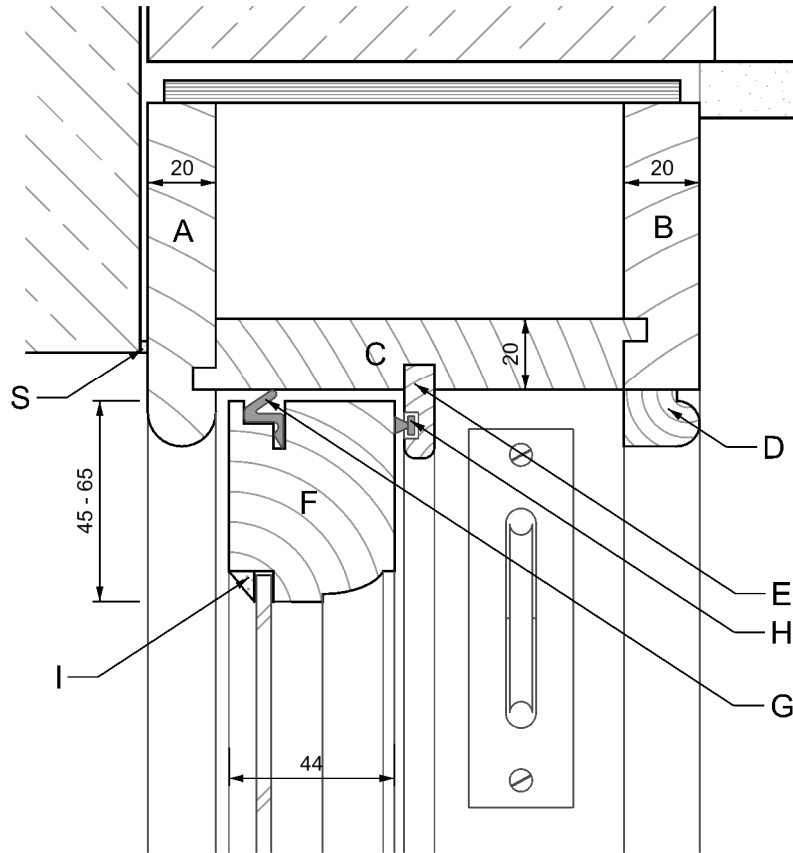

Sheet: V(A)-SG-04
Style: VICTORIAN SASH WINDOW
Glazing: Single Glazed
Drawing: Head and Meeting Rail
Scale: 1:2 @ A4

These drawings are intended for guidance only

LANCASTER
CITY COUNCIL
Promoting City, Coast & Countryside

- | | | | |
|---|---------------------------------------|---|-----------------------------------|
| A | OUTER LINING | K | TIMBER CILL (HARD WOOD OR ACCOYA) |
| B | INNER LINING | L | STONE CILL |
| C | SOFFIT LINING | M | BOTTOM RAIL |
| D | STAFF BEAD | N | WINDOW BOARD |
| E | PARTING BEAD | O | GLAZING BAR |
| F | TOP RAIL | P | SASH STILE |
| G | AQUAMAC 21 DRAUGHT SEAL OR EQUIVALENT | Q | PULLEY STILE |
| H | DRAUGHT STRIP | R | SASH WEIGHTS (CAST IRON OR LEAD) |
| I | GLAZING PUTTY | S | SEALANT POINTING |
| J | MEETING RAILS | | |

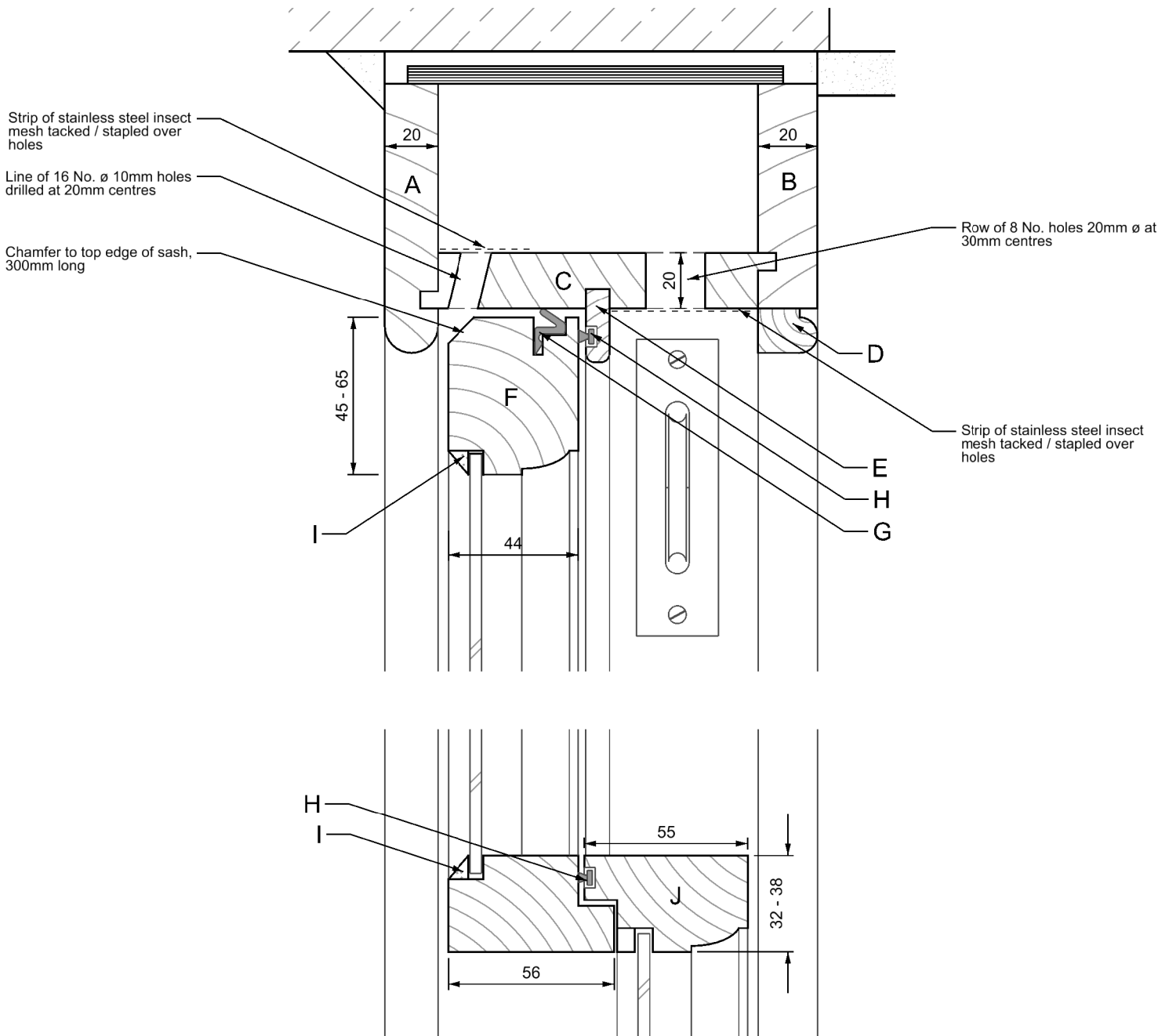

These drawings are intended for guidance only

LANCASTER CITY COUNCIL

Promoting City, Coast & Countryside

Sheet: V(A)-SG-05
Style: VICTORIAN SASH WINDOW
Glazing: Single Glazed
Drawing: Head with concealed trickle vent and Meeting Rail
Scale: 1:2 @ A4

- | | | | |
|---|---------------------------------------|---|-----------------------------------|
| A | OUTER LINING | K | TIMBER CILL (HARD WOOD OR ACCOYA) |
| B | INNER LINING | L | STONE CILL |
| C | SOFFIT LINING | M | BOTTOM RAIL |
| D | STAFF BEAD | N | WINDOW BOARD |
| E | PARTING BEAD | O | GLAZING BAR |
| F | TOP RAIL | P | SASH STILE |
| G | AQUAMAC 21 DRAUGHT SEAL OR EQUIVALENT | Q | PULLEY STILE |
| H | DRAUGHT STRIP | R | SASH WEIGHTS (CAST IRON OR LEAD) |
| I | GLAZING PUTTY | S | SEALANT POINTING |
| J | MEETING RAILS | | |

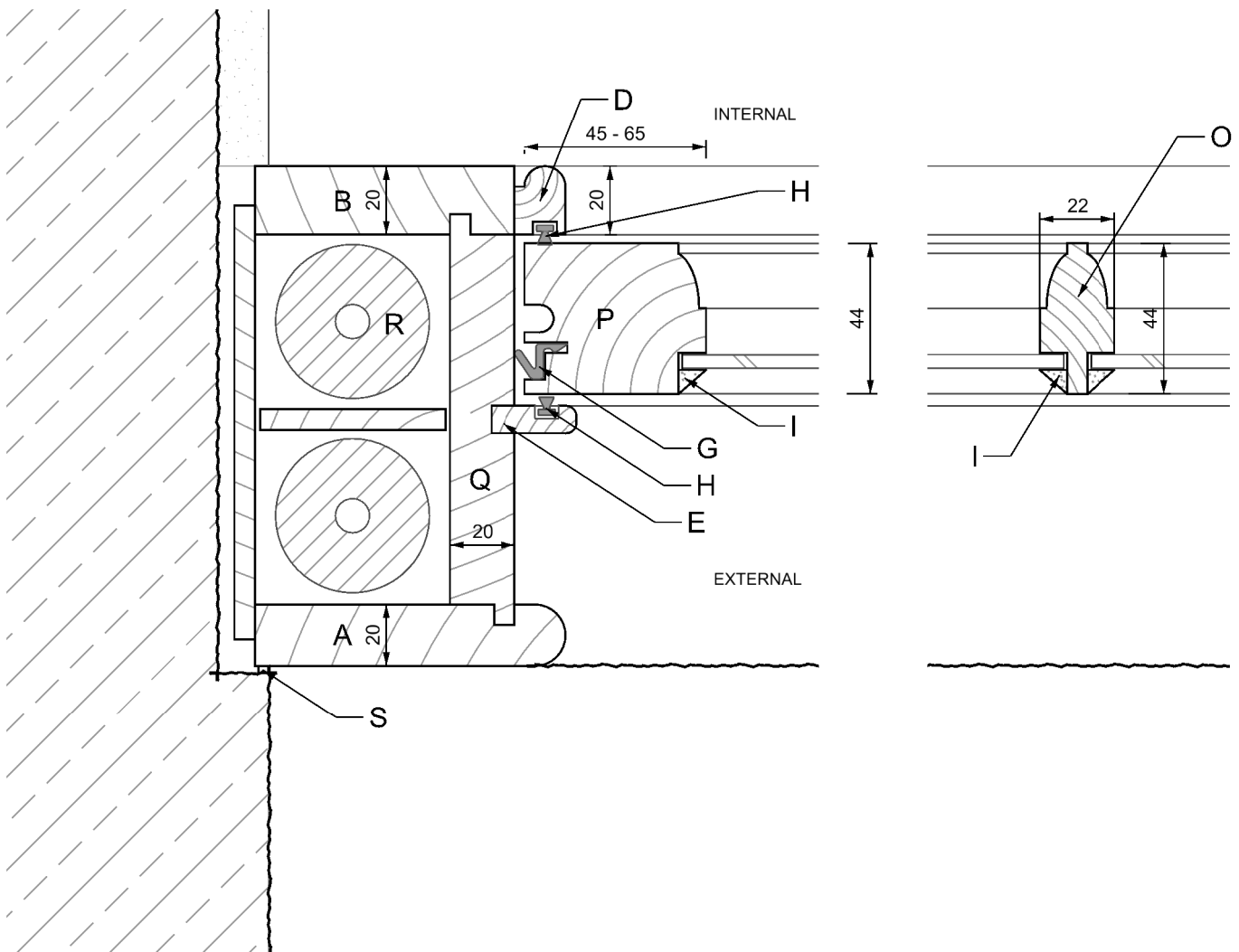

These drawings are intended for guidance only

LANCASTER CITY COUNCIL

Promoting City, Coast & Countryside

Sheet: V(A)-SG-06
Style: VICTORIAN SASH WINDOW
Glazing: Single Glazed
Drawing: Jamb and Glazing Bar
Scale: 1:2 @ A4

- | | | | |
|---|---------------------------------------|---|-----------------------------------|
| A | OUTER LINING | K | TIMBER CILL (HARD WOOD OR ACCOYA) |
| B | INNER LINING | L | STONE CILL |
| C | SOFFIT LINING | M | BOTTOM RAIL |
| D | STAFF BEAD | N | WINDOW BOARD |
| E | PARTING BEAD | O | GLAZING BAR |
| F | TOP RAIL | P | SASH STILE |
| G | AQUAMAC 21 DRAUGHT SEAL OR EQUIVALENT | Q | PULLEY STILE |
| H | DRAUGHT STRIP | R | SASH WEIGHTS (CAST IRON OR LEAD) |
| I | GLAZING PUTTY | S | SEALANT POINTING |
| J | MEETING RAILS | | |

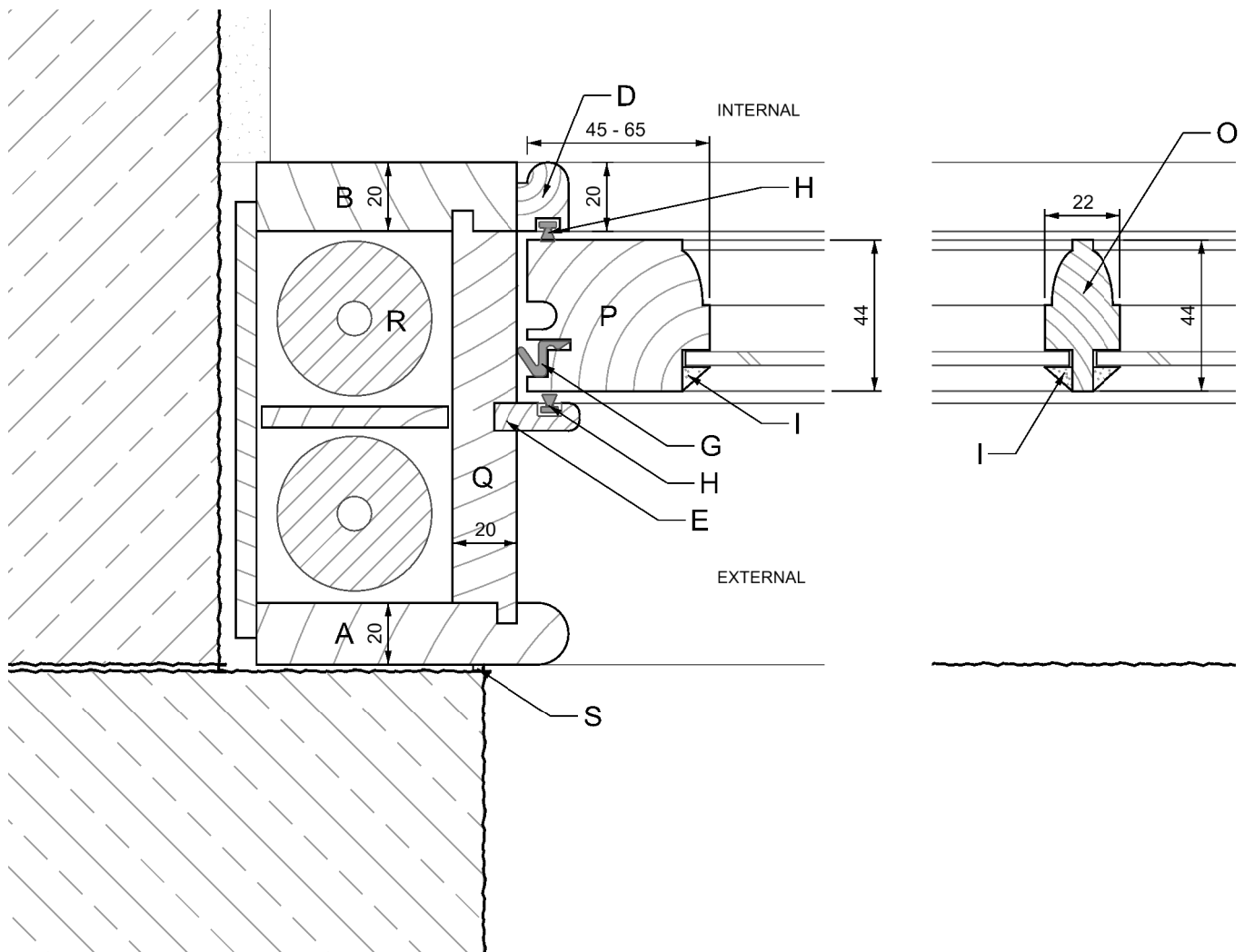

These drawings are intended for guidance only

LANCASTER CITY COUNCIL
Promoting City, Coast & Countryside

Sheet: V(A)-SG-07
 Style: VICTORIAN SASH WINDOW
 Glazing: Single Glazed
 Drawing: Jamb Rebated and Glazing Bar
 Scale: 1:2 @ A4

- | | | | |
|---|---------------------------------------|---|-----------------------------------|
| A | OUTER LINING | K | TIMBER CILL (HARD WOOD OR ACCOYA) |
| B | INNER LINING | L | STONE CILL |
| C | SOFFIT LINING | M | BOTTOM RAIL |
| D | STAFF BEAD | N | WINDOW BOARD |
| E | PARTING BEAD | O | GLAZING BAR |
| F | TOP RAIL | P | SASH STILE |
| G | AQUAMAC 21 DRAUGHT SEAL OR EQUIVALENT | Q | PULLEY STILE |
| H | DRAUGHT STRIP | R | SASH WEIGHTS (CAST IRON OR LEAD) |
| I | GLAZING PUTTY | S | SEALANT POINTING |
| J | MEETING RAILS | | |

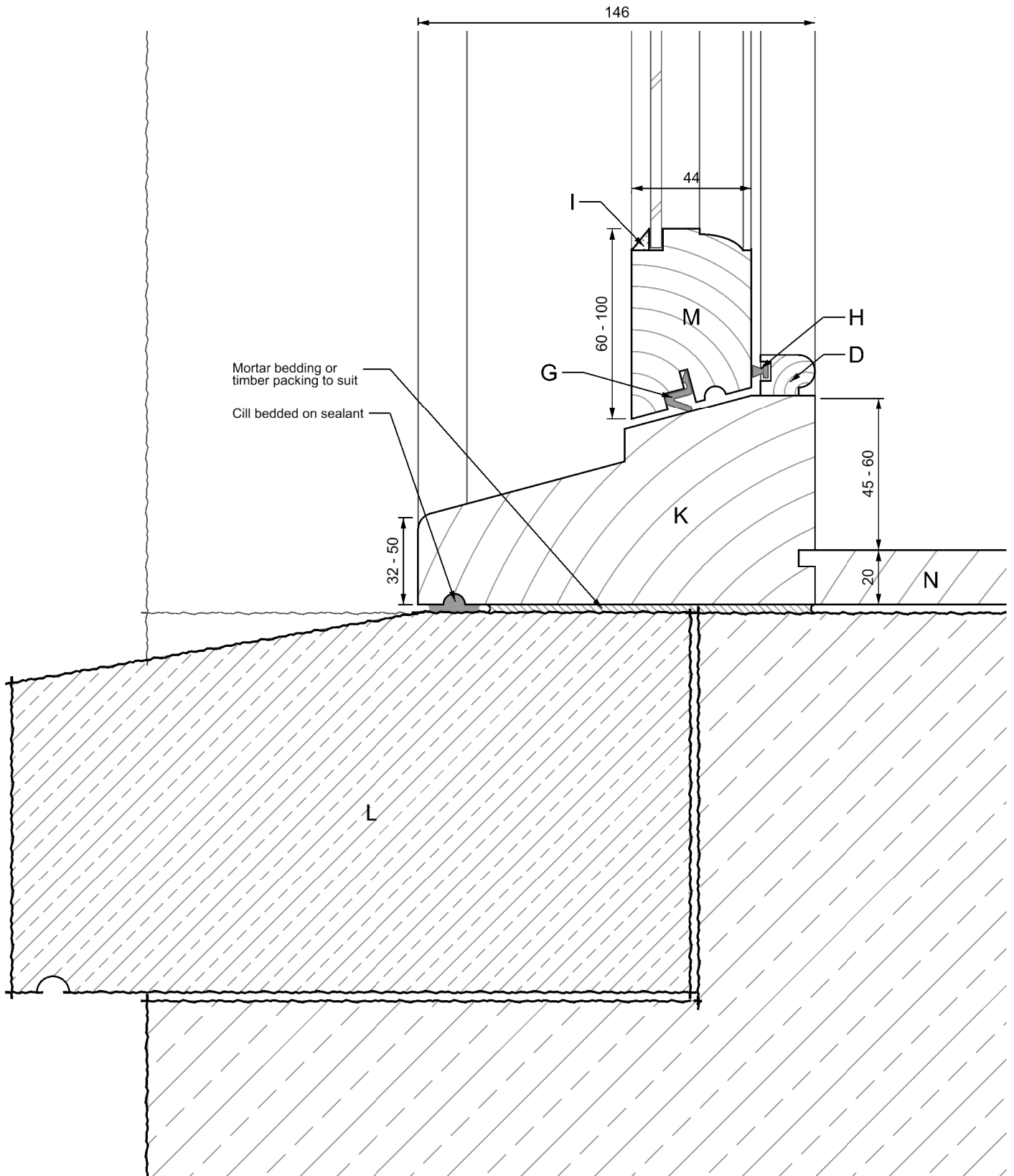

Mortar bedding or
timber packing to suit
Cill bedded on sealant

These drawings are
intended for guidance only

**LANCASTER
CITY COUNCIL**
Promoting City, Coast & Countryside

Sheet: V(A)-SG-01
Style: VICTORIAN SASH WINDOW
Glazing: Single Glazed
Drawing: Cill
Scale: 1:2 @ A4

- | | | | |
|---|---------------------------------------|---|-----------------------------------|
| A | OUTER LINING | K | TIMBER CILL (HARD WOOD OR ACCOYA) |
| B | INNER LINING | L | STONE CILL |
| C | SOFFIT LINING | M | BOTTOM RAIL |
| D | STAFF BEAD | N | WINDOW BOARD |
| E | PARTING BEAD | O | GLAZING BAR |
| F | TOP RAIL | P | SASH STILE |
| G | AQUAMAC 21 DRAUGHT SEAL OR EQUIVALENT | Q | PULLEY STILE |
| H | DRAUGHT STRIP | R | SASH WEIGHTS (CAST IRON OR LEAD) |
| I | GLAZING PUTTY | S | SEALANT POINTING |
| J | MEETING RAILS | | |

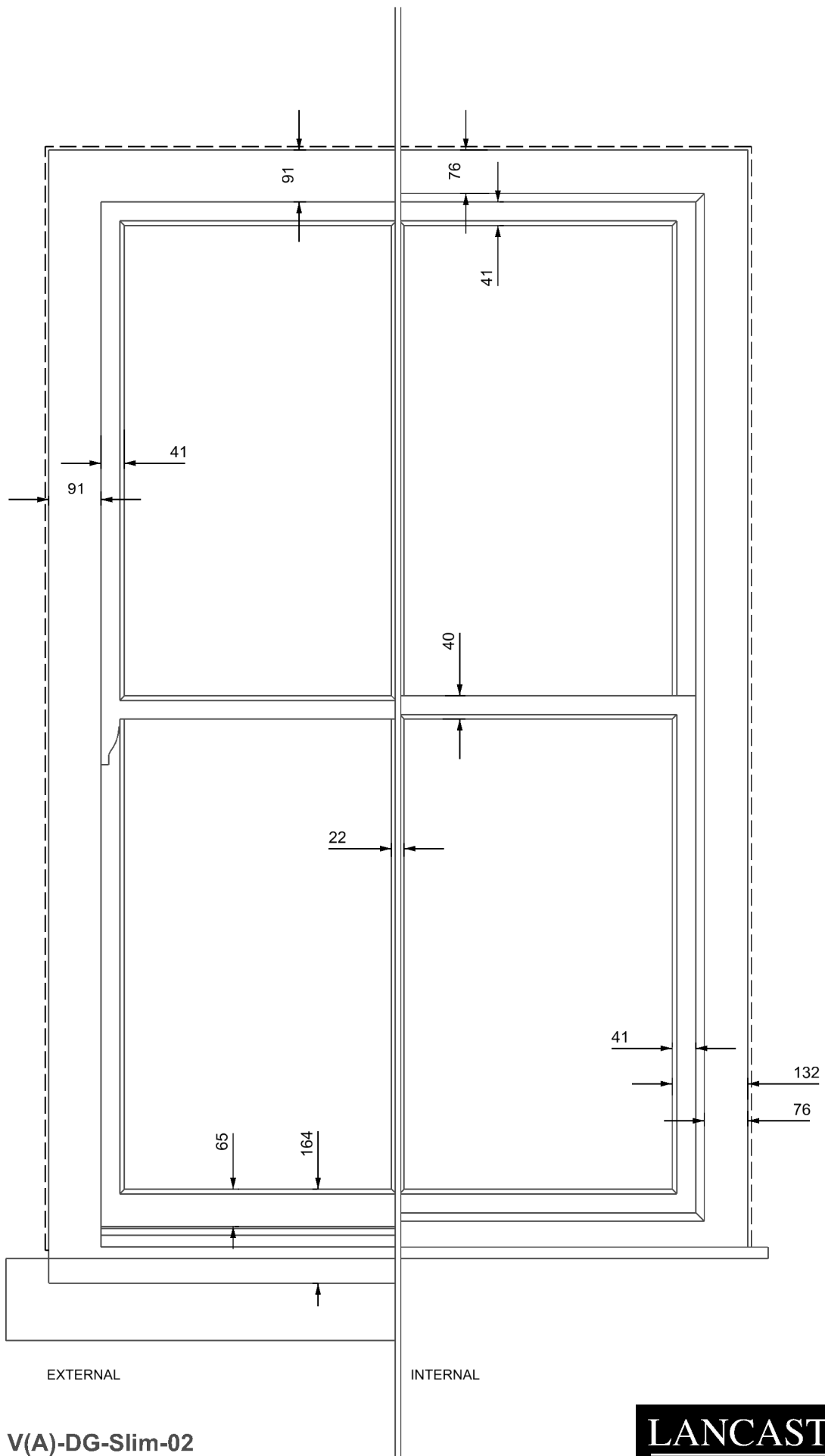

Sheet: V(A)-DG-Slim-02
Style: VICTORIAN SASH WINDOW
Glazing: Double Glazed (Slim 4/4/4)
Drawing: Internal and External Elevation
Scale: 1:10 @ A4

LANCASTER
CITY COUNCIL
Promoting City, Coast & Countryside

These drawings are intended for guidance only

LANCASTER CITY COUNCIL

Promoting City, Coast & Countryside

These drawings are intended for guidance only

- A OUTER LINING
- B INNER LINING
- C SOFFIT LINING
- D STAFF BEAD
- E PARTING BEAD
- F TOP RAIL
- G AQUAMAC 21 DRAUGHT SEAL OR EQUIVALENT
- H DRAUGHT STRIP
- I GLAZING PUTTY
- J MEETING RAILS
- K TIMBER CILL (HARD WOOD OR ACCOYA)
- L STONE CILL
- M BOTTOM RAIL
- N WINDOW BOARD
- O GLAZING BAR
- P SASH STILE
- Q PULLEY STILE
- R SASH WEIGHTS (CAST IRON OR LEAD)
- S SEALANT POINTING

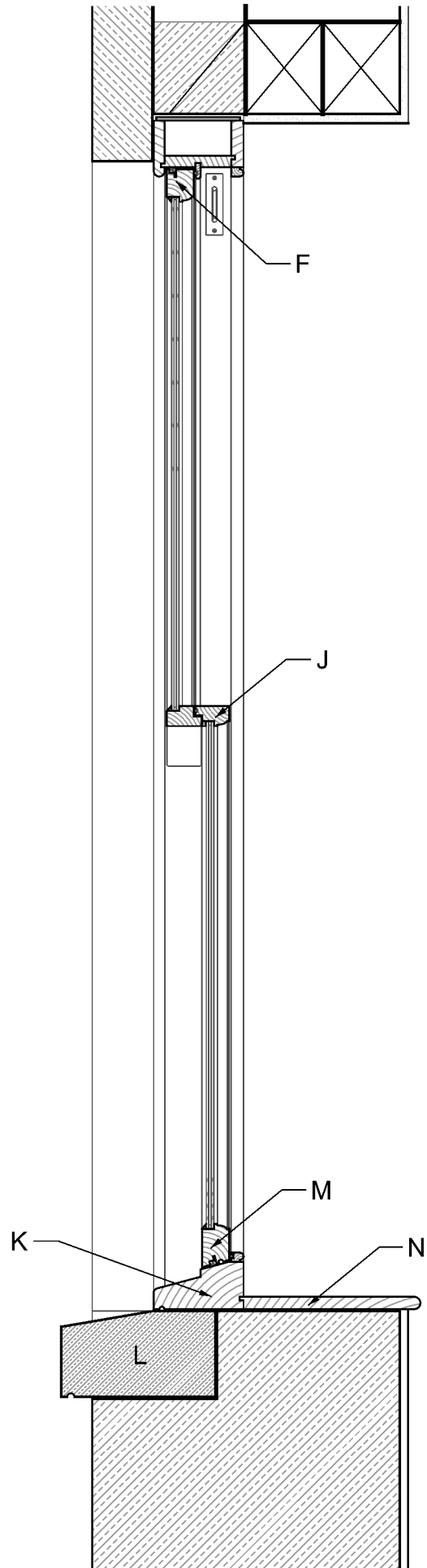

Sheet: V(A)-DG-Slim-03

Style: VICTORIAN SASH WINDOW

Glazing: Double Glazed (Slim 4/4/4)

Drawing: Full Section

Scale: 1:10 @ A4

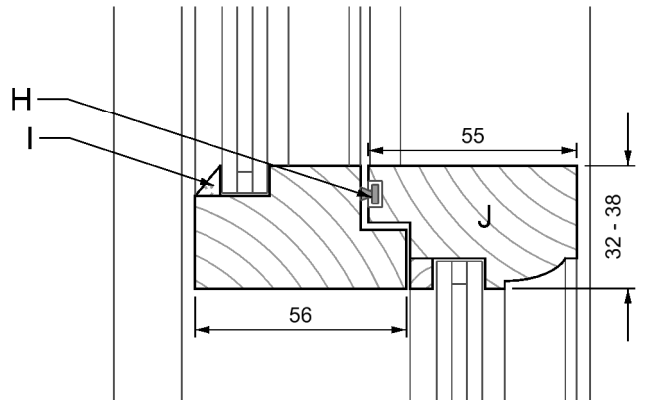
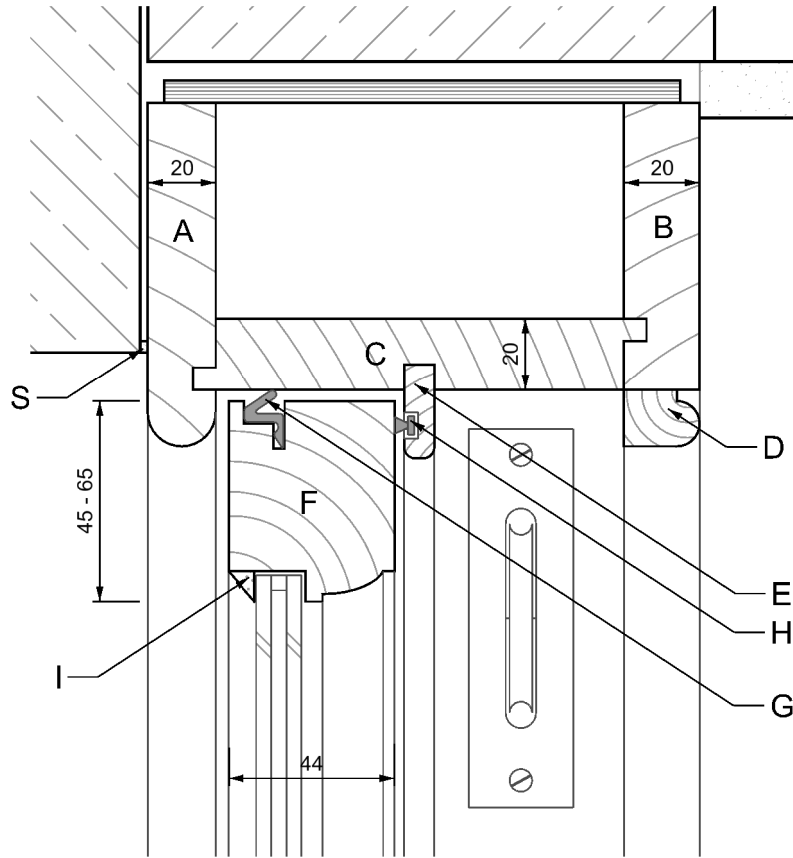

These drawings are intended for guidance only

LANCASTER CITY COUNCIL
Promoting City, Coast & Countryside

Sheet: V(A)-DG-Slim-04
 Style: VICTORIAN SASH WINDOW
 Glazing: Double Glazed (Slim 4/4/4)
 Drawing: Head and Meeting Rail
 Scale: 1:2 @ A4

- | | | | |
|---|---------------------------------------|---|-----------------------------------|
| A | OUTER LINING | K | TIMBER CILL (HARD WOOD OR ACCOYA) |
| B | INNER LINING | L | STONE CILL |
| C | SOFFIT LINING | M | BOTTOM RAIL |
| D | STAFF BEAD | N | WINDOW BOARD |
| E | PARTING BEAD | O | GLAZING BAR |
| F | TOP RAIL | P | SASH STILE |
| G | AQUAMAC 21 DRAUGHT SEAL OR EQUIVALENT | Q | PULLEY STILE |
| H | DRAUGHT STRIP | R | SASH WEIGHTS (CAST IRON OR LEAD) |
| I | GLAZING PUTTY | S | SEALANT POINTING |
| J | MEETING RAILS | | |

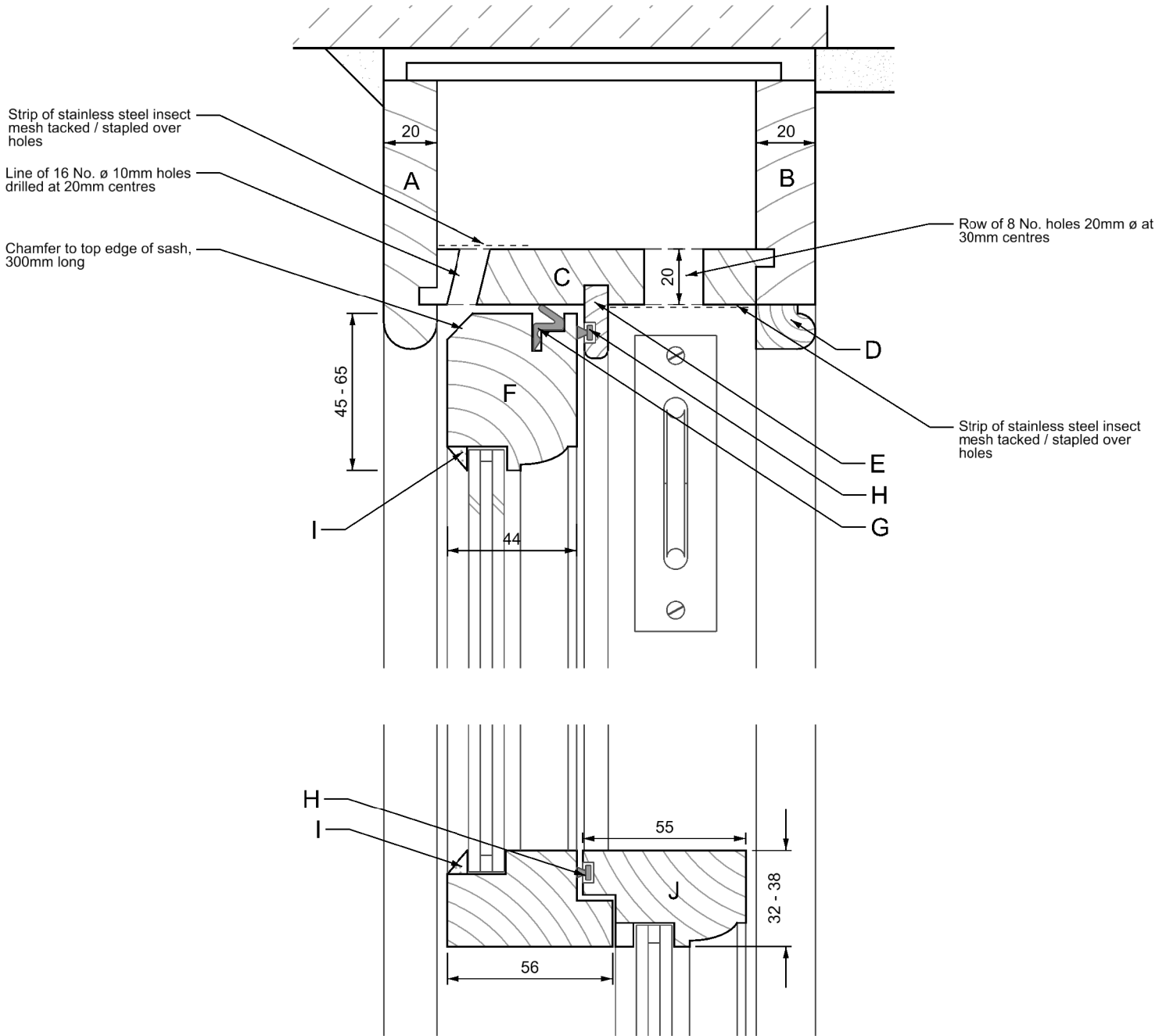

Sheet: V(A)-DG-Slim-05

Style: VICTORIAN SASH WINDOW

Glazing: Double Glazed (Slim 4/4/4)

Drawing: Head with concealed trickle vent and Meeting Rail

Scale: 1:2 @ A4

These drawings are intended for guidance only

LANCASTER CITY COUNCIL
Promoting City, Coast & Countryside

A	OUTER LINING	K	TIMBER CILL (HARD WOOD OR ACCOYA)
B	INNER LINING	L	STONE CILL
C	SOFFIT LINING	M	BOTTOM RAIL
D	STAFF BEAD	N	WINDOW BOARD
E	PARTING BEAD	O	GLAZING BAR
F	TOP RAIL	P	SASH STILE
G	AQUAMAC 21 DRAUGHT SEAL OR EQUIVALENT	Q	PULLEY STILE
H	DRAUGHT STRIP	R	SASH WEIGHTS (CAST IRON OR LEAD)
I	GLAZING PUTTY	S	SEALANT POINTING
J	MEETING RAILS		

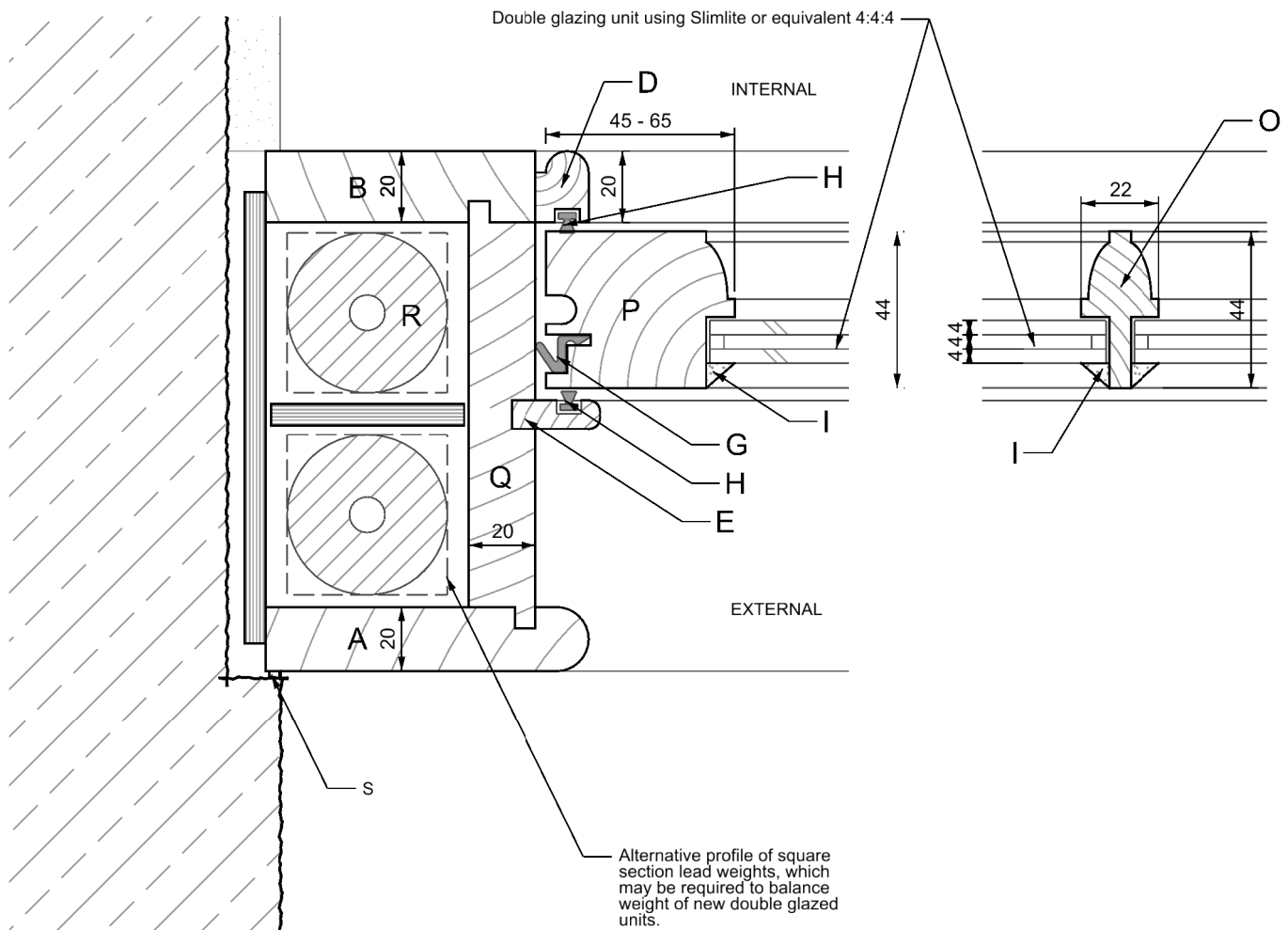

**LANCASTER
CITY COUNCIL**
Promoting City, Coast & Countryside

These drawings are intended for guidance only

Sheet: V(A)-DG-Slim-06
Style: VICTORIAN SASH WINDOW
Glazing: Double Glazed (Slim 4/4/4)
Drawing: Jamb and Glazing Bar
Scale: 1:2 @ A4

A	OUTER LINING	K	TIMBER CILL (HARD WOOD OR ACCOYA)
B	INNER LINING	L	STONE CILL
C	SOFFIT LINING	M	BOTTOM RAIL
D	STAFF BEAD	N	WINDOW BOARD
E	PARTING BEAD	O	GLAZING BAR
F	TOP RAIL	P	SASH STILE
G	AQUAMAC 21 DRAUGHT SEAL OR EQUIVALENT	Q	PULLEY STILE
H	DRAUGHT STRIP	R	SASH WEIGHTS (CAST IRON OR LEAD)
I	GLAZING PUTTY	S	SEALANT POINTING
J	MEETING RAILS		

NOTES:

Glazing - replacement single glazing typically 4mm thick. Upgrade "slim" double glazing units typically 4/4/4mm if rebates can be adapted to suit.
Putty - for single glazing traditional linseed putty may be used. Double glazed units may require polymer glazing putty according to the d.g. unit manufacturers recommendation.

Timber - for "pieced-in" repairs use tight grained softwood to match existing as closely as possible e.g. redwood, Douglas Fir, free of knots.

Replacement cills or complete new elements may use a durable hardwood.

Finishes - Traditional linseed oil paint, or a micro-porous paint system.

*Note that heavier d.g. units will require heavier sash weights in cast iron or lead.

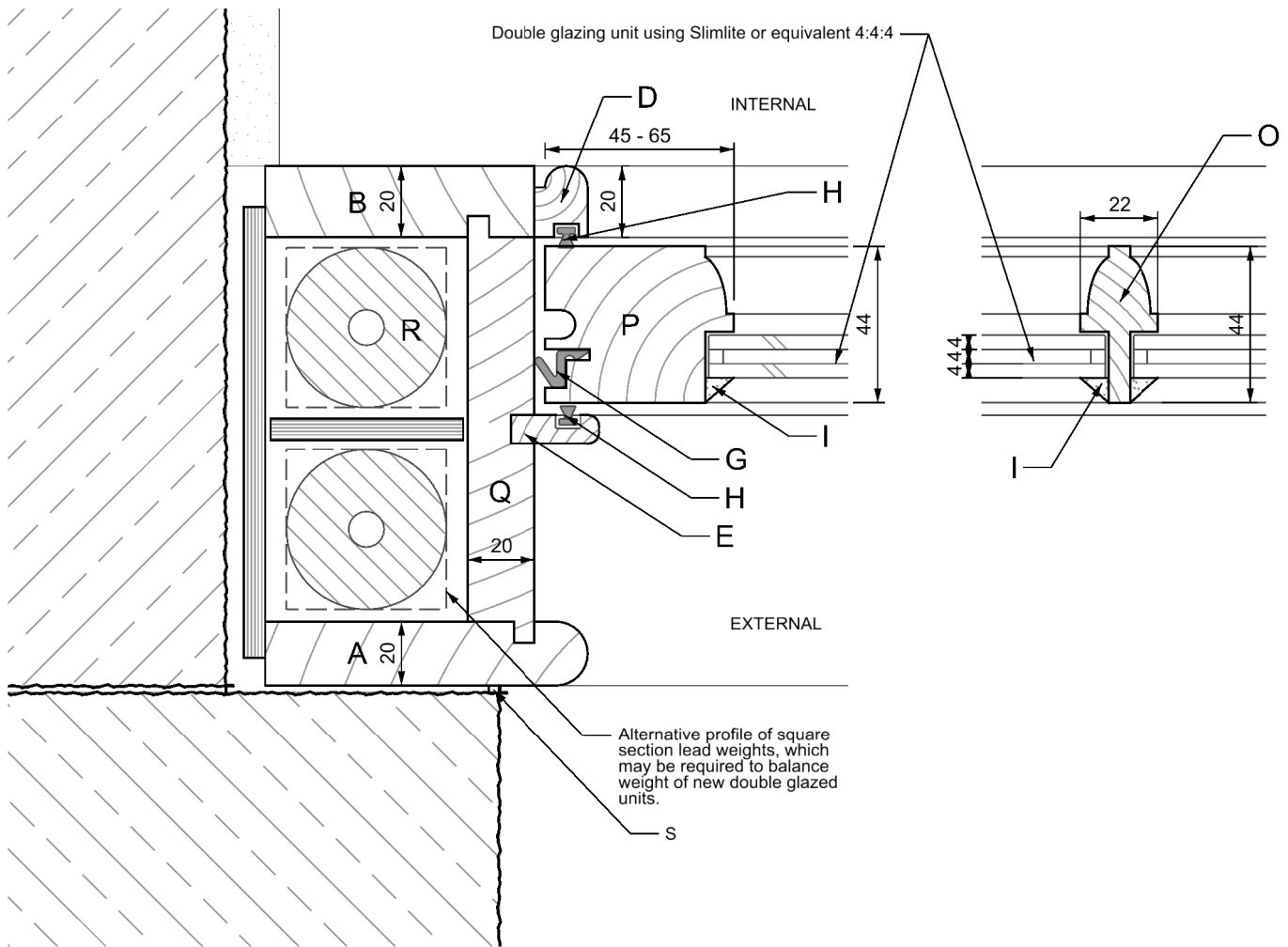

These drawings are intended for guidance only

LANCASTER CITY COUNCIL
Promoting City, Coast & Countryside

Sheet: V(A)-DG-Slim-07
Style: VICTORIAN SASH WINDOW
Glazing: Double Glazed (Slim 4/4/4)
Drawing: Jamb Rebated and Glazing Bar
Scale: 1:2 @ A4

A	OUTER LINING	K	TIMBER CILL (HARD WOOD OR ACCOYA)
B	INNER LINING	L	STONE CILL
C	SOFFIT LINING	M	BOTTOM RAIL
D	STAFF BEAD	N	WINDOW BOARD
E	PARTING BEAD	O	GLAZING BAR
F	TOP RAIL	P	SASH STILE
G	AQUAMAC 21 DRAUGHT SEAL OR EQUIVALENT	Q	PULLEY STILE
H	DRAUGHT STRIP	R	SASH WEIGHTS (CAST IRON OR LEAD)
I	GLAZING PUTTY	S	SEALANT POINTING
J	MEETING RAILS		

NOTES:

Glazing - replacement single glazing typically 4mm thick. Upgrade "slim" double glazing units typically 4/4/4mm if rebates can be adapted to suit.
Putty - for single glazing traditional linseed putty may be used. Double glazed units may require polymer glazing putty according to the d.g. unit manufacturers recommendation.

Timber - for "pieced-in" repairs use tight grained softwood to match existing as closely as possible e.g. redwood, Douglas Fir, free of knots.

Replacement cills or complete new elements may use a durable hardwood.

Finishes - Traditional linseed oil paint, or a micro-porous paint system.

*Note that heavier d.g. units will require heavier sash weights in cast iron or lead.

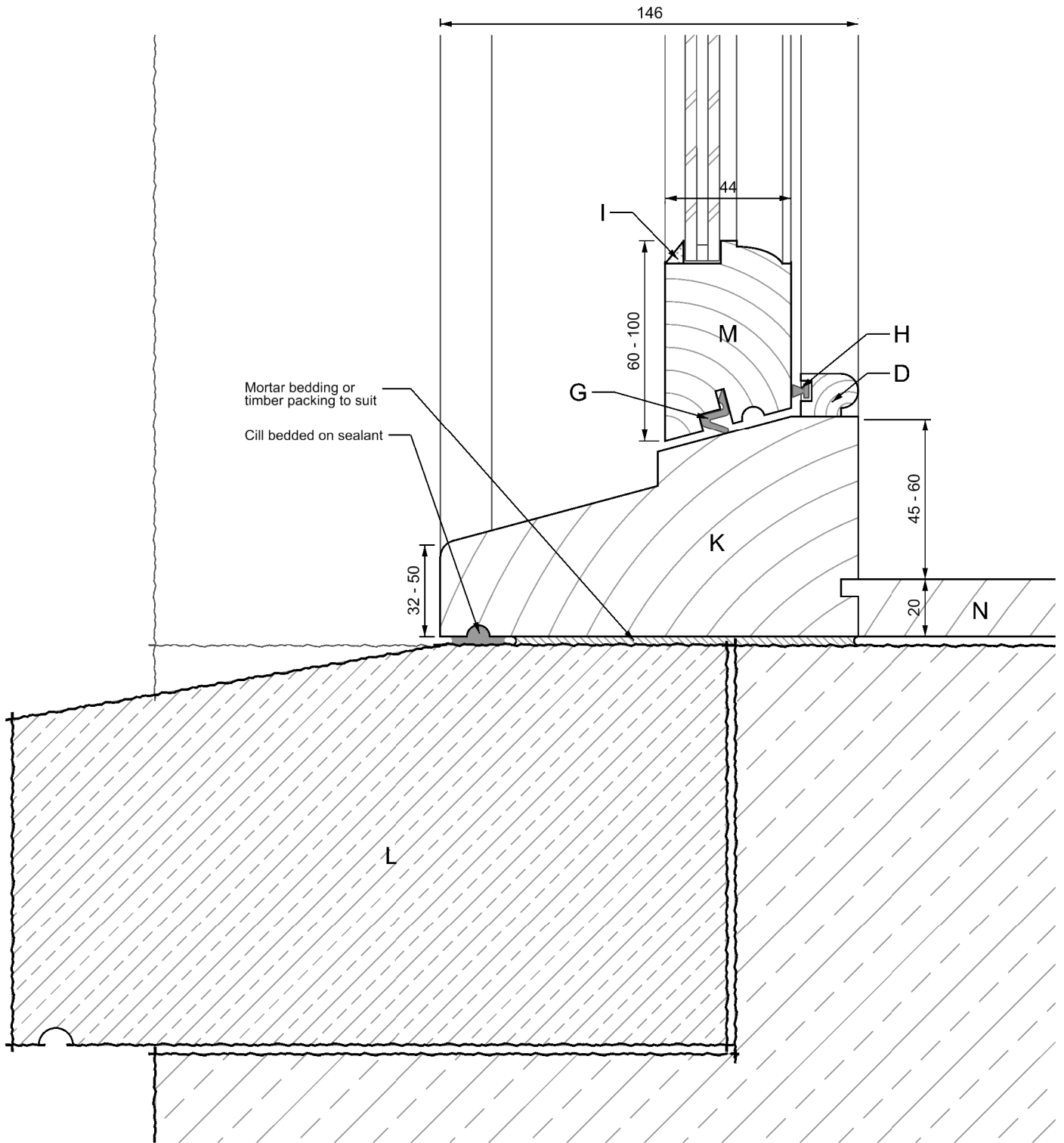

These drawings are intended for guidance only

LANCASTER CITY COUNCIL
Promoting City, Coast & Countryside

Sheet: V(A)-DG-Slim-01
 Style: VICTORIAN SASH WINDOW
 Glazing: Double Glazed (Slim 4/4/4)
 Drawing: Cill
 Scale: 1:2 @ A4

- | | | | |
|---|---------------------------------------|---|-----------------------------------|
| A | OUTER LINING | K | TIMBER CILL (HARD WOOD OR ACCOYA) |
| B | INNER LINING | L | STONE CILL |
| C | SOFFIT LINING | M | BOTTOM RAIL |
| D | STAFF BEAD | N | WINDOW BOARD |
| E | PARTING BEAD | O | GLAZING BAR |
| F | TOP RAIL | P | SASH STILE |
| G | AQUAMAC 21 DRAUGHT SEAL OR EQUIVALENT | Q | PULLEY STILE |
| H | DRAUGHT STRIP | R | SASH WEIGHTS (CAST IRON OR LEAD) |
| I | GLAZING PUTTY | S | SEALANT POINTING |
| J | MEETING RAILS | | |

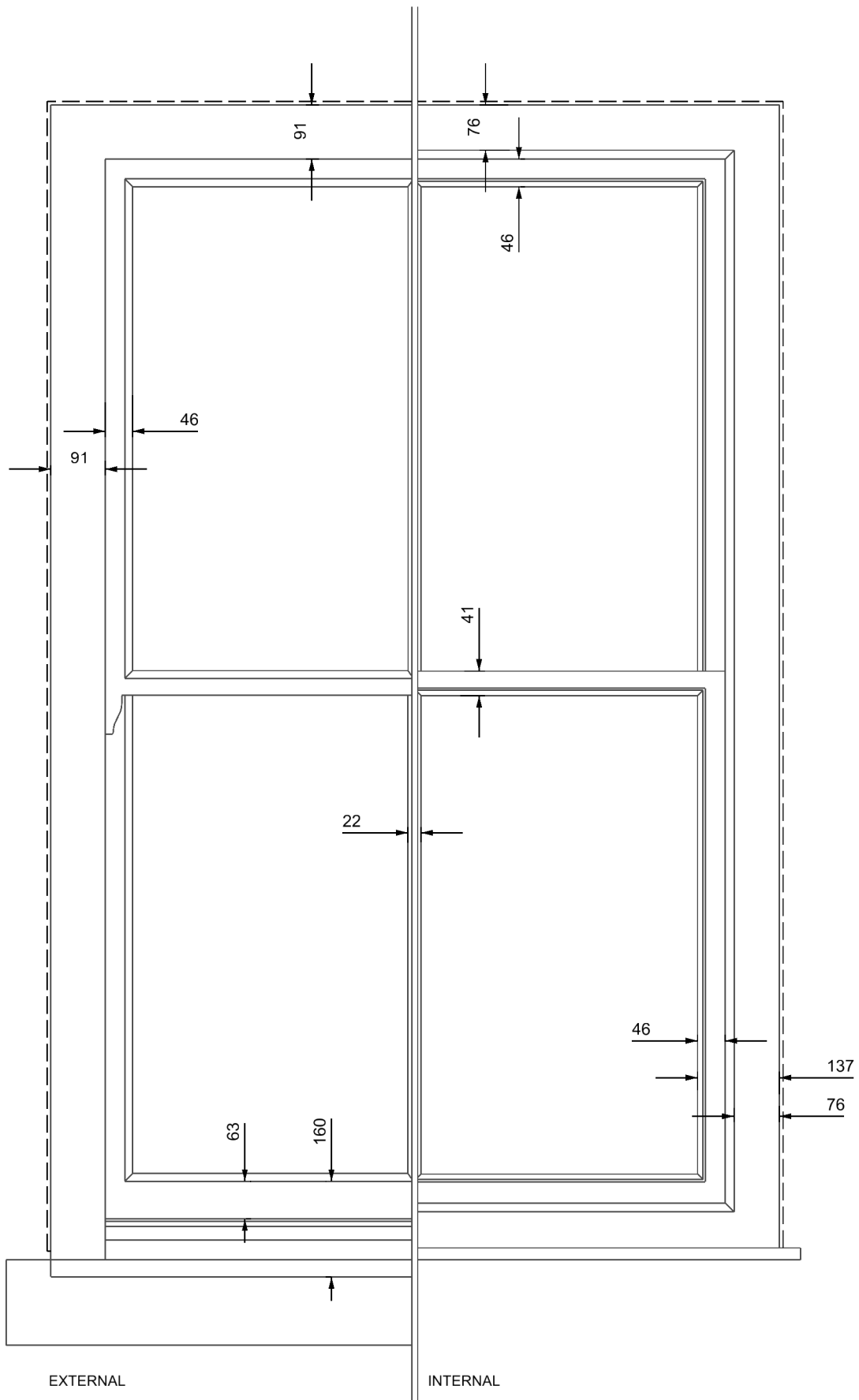

Sheet: V(A)-DG-Stand-02
Style: VICTORIAN SASH WINDOW
Glazing: Double Glazed (Standard 4/16/4)
Drawing: Internal and External Elevation
Scale: 1:10 @ A4



These drawings are intended for guidance only

LANCASTER CITY COUNCIL

Promoting City, Coast & Countryside

These drawings are intended for guidance only

- A OUTER LINING
- B INNER LINING
- C SOFFIT LINING
- D STAFF BEAD
- E PARTING BEAD
- F TOP RAIL
- G AQUAMAC 21 DRAUGHT SEAL OR EQUIVALENT
- H DRAUGHT STRIP
- I GLAZING PUTTY
- J MEETING RAILS
- K TIMBER CILL (HARD WOOD OR ACCOYA)
- L STONE CILL
- M BOTTOM RAIL
- N WINDOW BOARD
- O GLAZING BAR
- P SASH STILE
- Q PULLEY STILE
- R SASH WEIGHTS (CAST IRON OR LEAD)
- S SEALANT POINTING

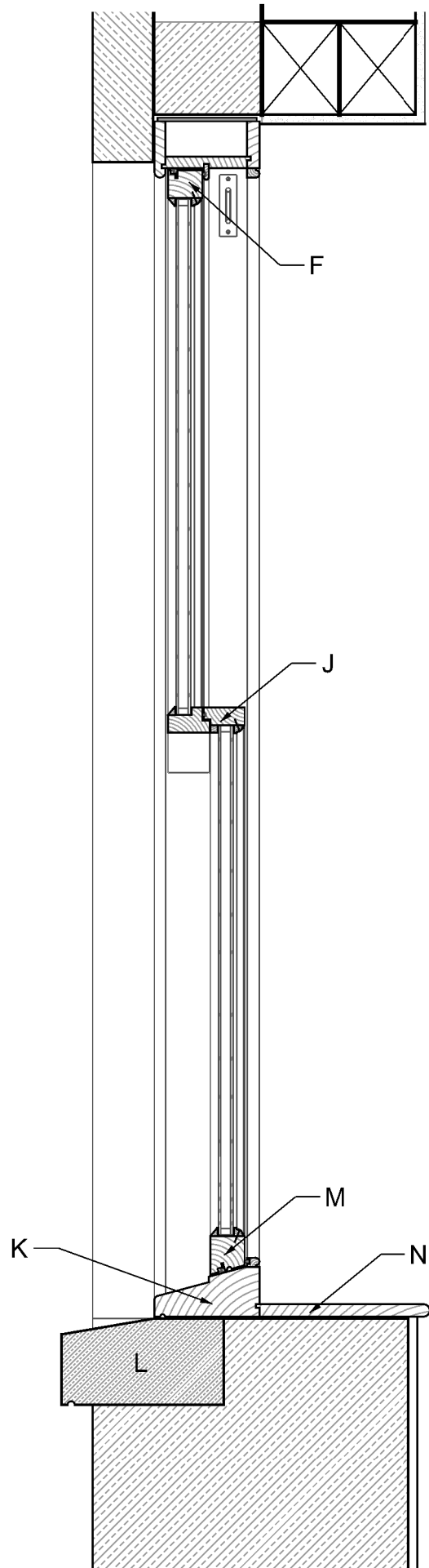

Sheet: V(A)-DG-Stand-03

Style: VICTORIAN SASH WINDOW
 Glazing: Double Glazed (Standard 4/16/4)
 Drawing: Full Section

Scale: 1:10 @ A4

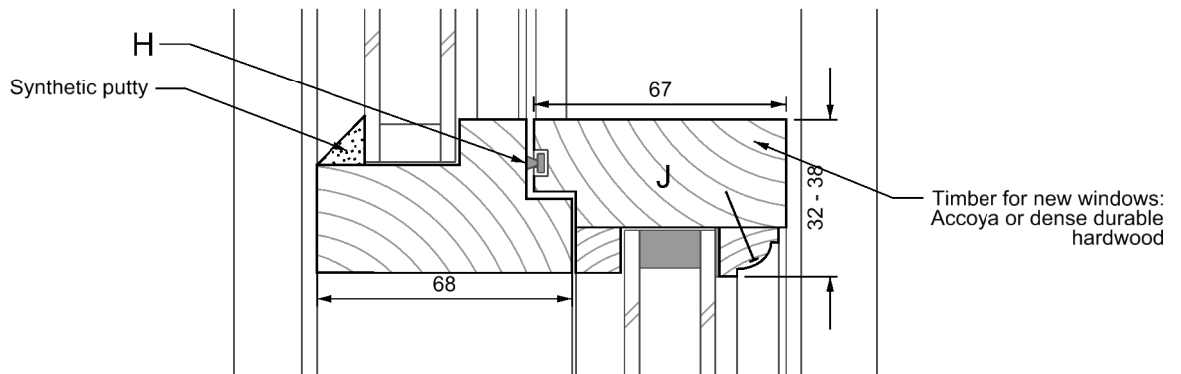
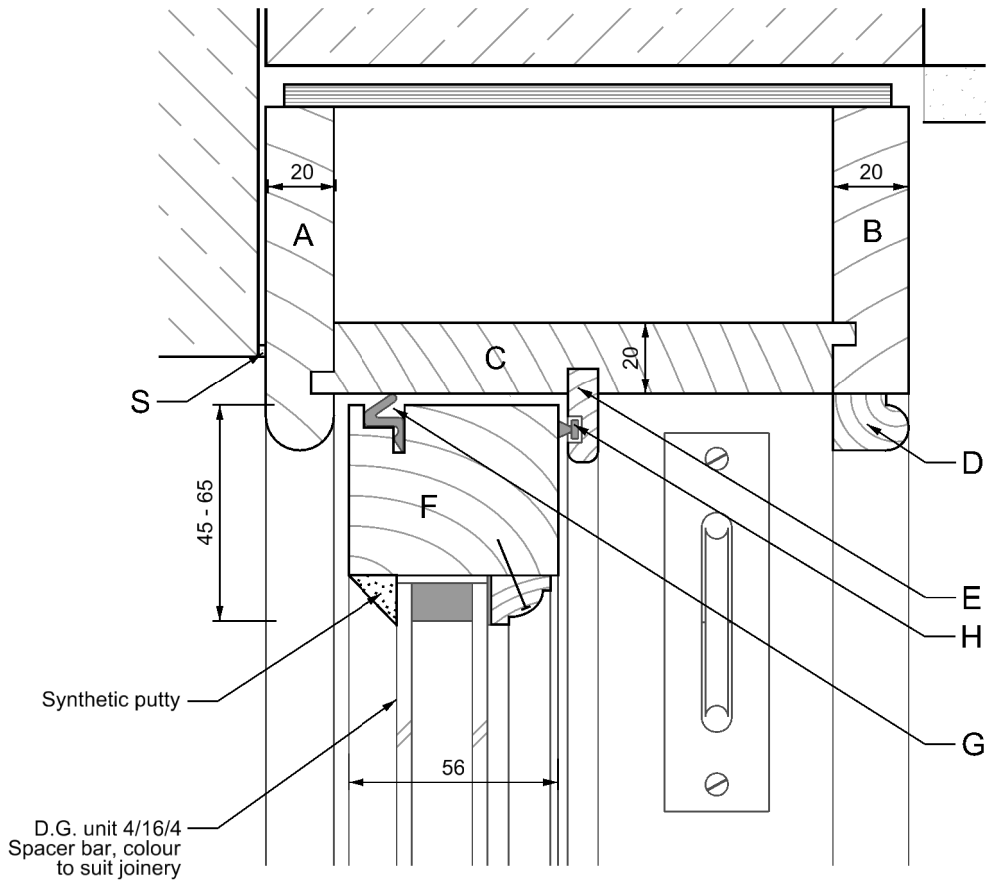

LANCASTER
CITY COUNCIL
Promoting City, Coast & Countryside

These drawings are intended for guidance only

Sheet: V(A)-DG-Stand-04
Style: VICTORIAN SASH WINDOW
Glazing: Double Glazed (Standard 4/16/4)
Drawing: Head and Meeting Rail
Scale: 1:2 @ A4

A	OUTER LINING	K	TIMBER CILL (HARD WOOD OR ACCOYA)
B	INNER LINING	L	STONE CILL
C	SOFFIT LINING	M	BOTTOM RAIL
D	STAFF BEAD	N	WINDOW BOARD
E	PARTING BEAD	O	GLAZING BAR
F	TOP RAIL	P	SASH STILE
G	AQUAMAC 21 DRAUGHT SEAL OR EQUIVALENT	Q	PULLEY STILE
H	DRAUGHT STRIP	R	SASH WEIGHTS (CAST IRON OR LEAD)
I	GLAZING PUTTY	S	SEALANT POINTING
J	MEETING RAILS		

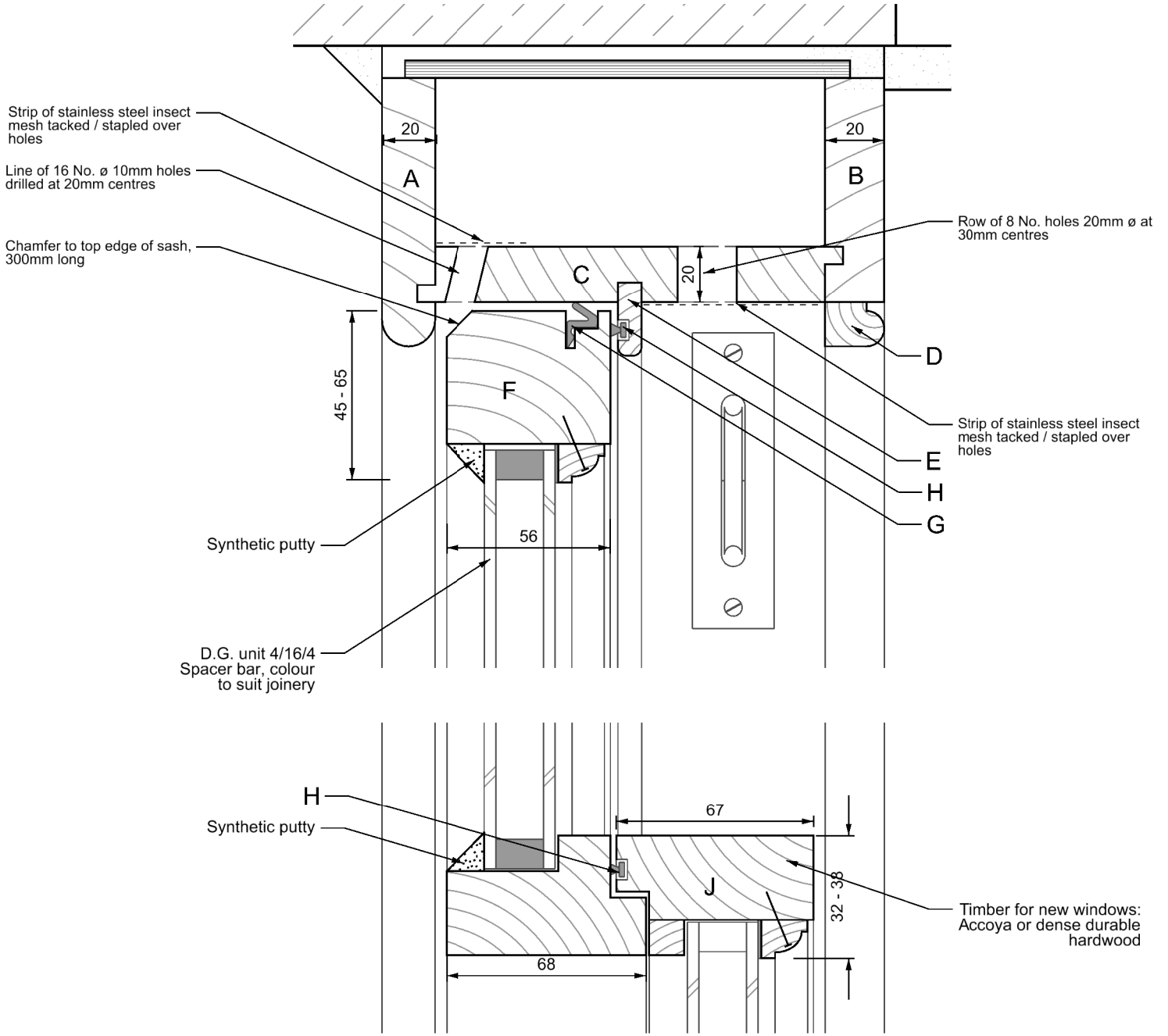

LANCASTER
CITY COUNCIL

Promoting City, Coast & Countryside

These drawings are intended for guidance only

Sheet: V(A)-DG-Stand-05
Style: VICTORIAN SASH WINDOW
Glazing: Double Glazed (Standard 4/16/4)
Drawing: Head with concealed trickle vent and Meeting Rail
Scale: 1:2 @ A4

- | | | | |
|---|---------------------------------------|---|-----------------------------------|
| A | OUTER LINING | K | TIMBER CILL (HARD WOOD OR ACCOYA) |
| B | INNER LINING | L | STONE CILL |
| C | SOFFIT LINING | M | BOTTOM RAIL |
| D | STAFF BEAD | N | WINDOW BOARD |
| E | PARTING BEAD | O | GLAZING BAR |
| F | TOP RAIL | P | SASH STILE |
| G | AQUAMAC 21 DRAUGHT SEAL OR EQUIVALENT | Q | PULLEY STILE |
| H | DRAUGHT STRIP | R | SASH WEIGHTS (CAST IRON OR LEAD) |
| I | GLAZING PUTTY | S | SEALANT POINTING |
| J | MEETING RAILS | | |

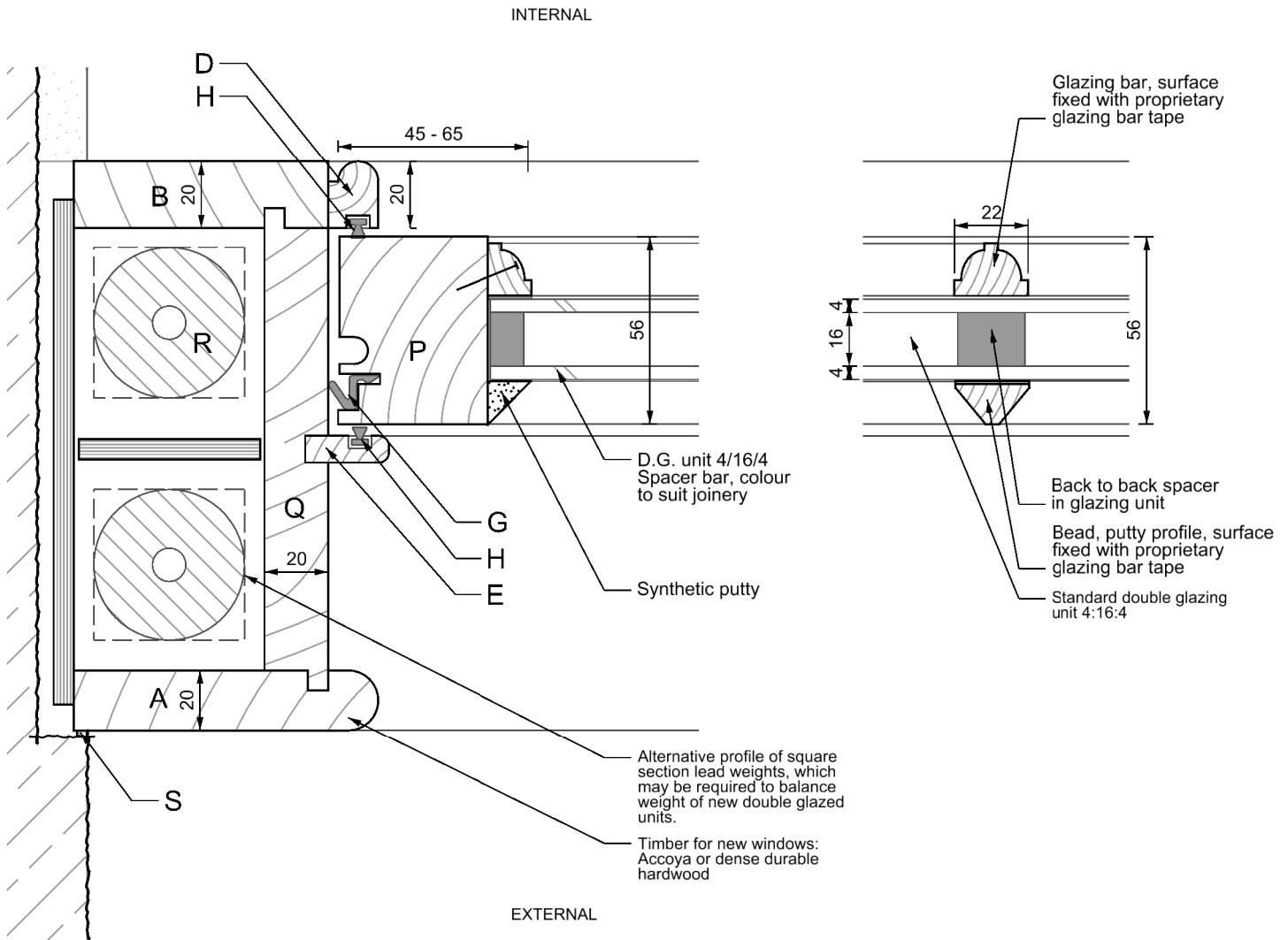

These drawings are intended for guidance only

LANCASTER CITY COUNCIL

Promoting City, Coast & Countryside

Sheet: V(A)-DG-Stand-06
Style: VICTORIAN SASH WINDOW
Glazing: Double Glazed (Standard 4/16/4)
Drawing: Jamb and Glazing Bar
Scale: 1:2 @ A4

A	OUTER LINING	K	TIMBER CILL (HARD WOOD OR ACCOYA)
B	INNER LINING	L	STONE CILL
C	SOFFIT LINING	M	BOTTOM RAIL
D	STAFF BEAD	N	WINDOW BOARD
E	PARTING BEAD	O	GLAZING BAR
F	TOP RAIL	P	SASH STILE
G	AQUAMAC 21 DRAUGHT SEAL OR EQUIVALENT	Q	PULLEY STILE
H	DRAUGHT STRIP	R	SASH WEIGHTS (CAST IRON OR LEAD)
I	GLAZING PUTTY	S	SEALANT POINTING
J	MEETING RAILS		

NOTES:
 Glazing - replacement single glazing typically 4mm thick. Upgrade "slim" double glazing units typically 4/4/4mm if rebates can be adapted to suit.
 Putty - for single glazing traditional linseed putty may be used. Double glazed units may require polymer glazing putty according to the d.g. unit manufacturers recommendation.
 Timber - for "pieced-in" repairs use tight grained softwood to match existing as closely as possible e.g. redwood, Douglas Fir, free of knots.
 Replacement cills or complete new elements may use a durable hardwood.
 Finishes - Traditional linseed oil paint, or a micro-porous paint system.
 *Note that heavier d.g. units will require heavier sash weights in cast iron or lead.

INTERNAL

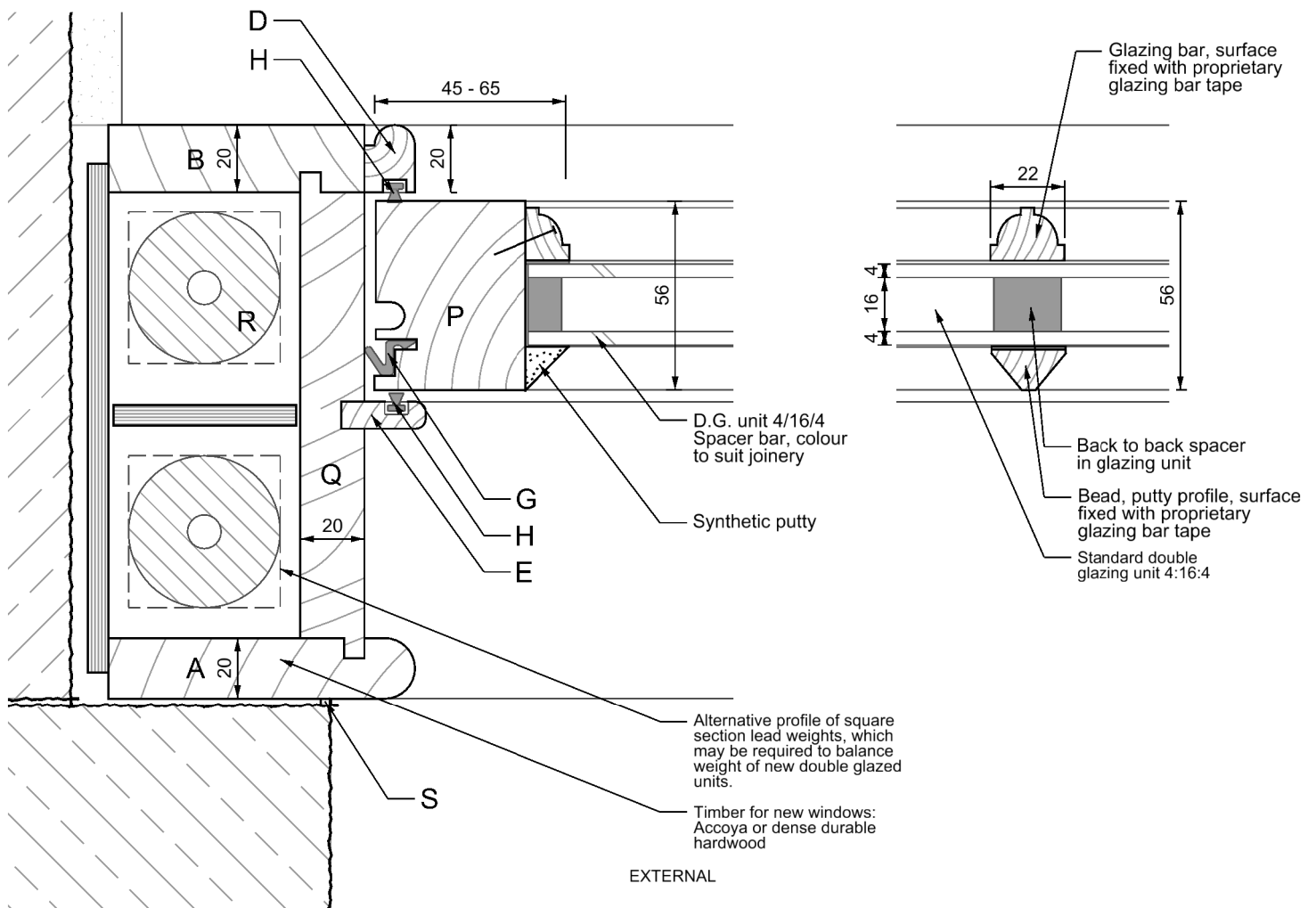

These drawings are intended for guidance only

Sheet: V(A)-DG-Stand-07
Style: VICTORIAN SASH WINDOW
Glazing: Double Glazed (Standard 4/16/4)
Drawing: Jamb Rebated and Glazing Bar
Scale: 1:2 @ A4

A	OUTER LINING	K	TIMBER CILL (HARD WOOD OR ACCOYA)
B	INNER LINING	L	STONE CILL
C	SOFFIT LINING	M	BOTTOM RAIL
D	STAFF BEAD	N	WINDOW BOARD
E	PARTING BEAD	O	GLAZING BAR
F	TOP RAIL	P	SASH STILE
G	AQUAMAC 21 DRAUGHT SEAL OR EQUIVALENT	Q	PULLEY STILE
H	DRAUGHT STRIP	R	SASH WEIGHTS (CAST IRON OR LEAD)
I	GLAZING PUTTY	S	SEALANT POINTING
J	MEETING RAILS		

NOTES:
 Glazing - replacement single glazing typically 4mm thick. Upgrade "slim" double glazing units typically 4/4/4mm if rebates can be adapted to suit.
 Putty - for single glazing traditional linseed putty may be used. Double glazed units may require polymer glazing putty according to the d.g. unit manufacturers recommendation.
 Timber - for "pieced-in" repairs use tight grained softwood to match existing as closely as possible e.g. redwood, Douglas Fir, free of knots.
 Replacement cills or complete new elements may use a durable hardwood.
 Finishes - Traditional linseed oil paint, or a micro-porous paint system.
 *Note that heavier d.g. units will require heavier sash weights in cast iron or lead.

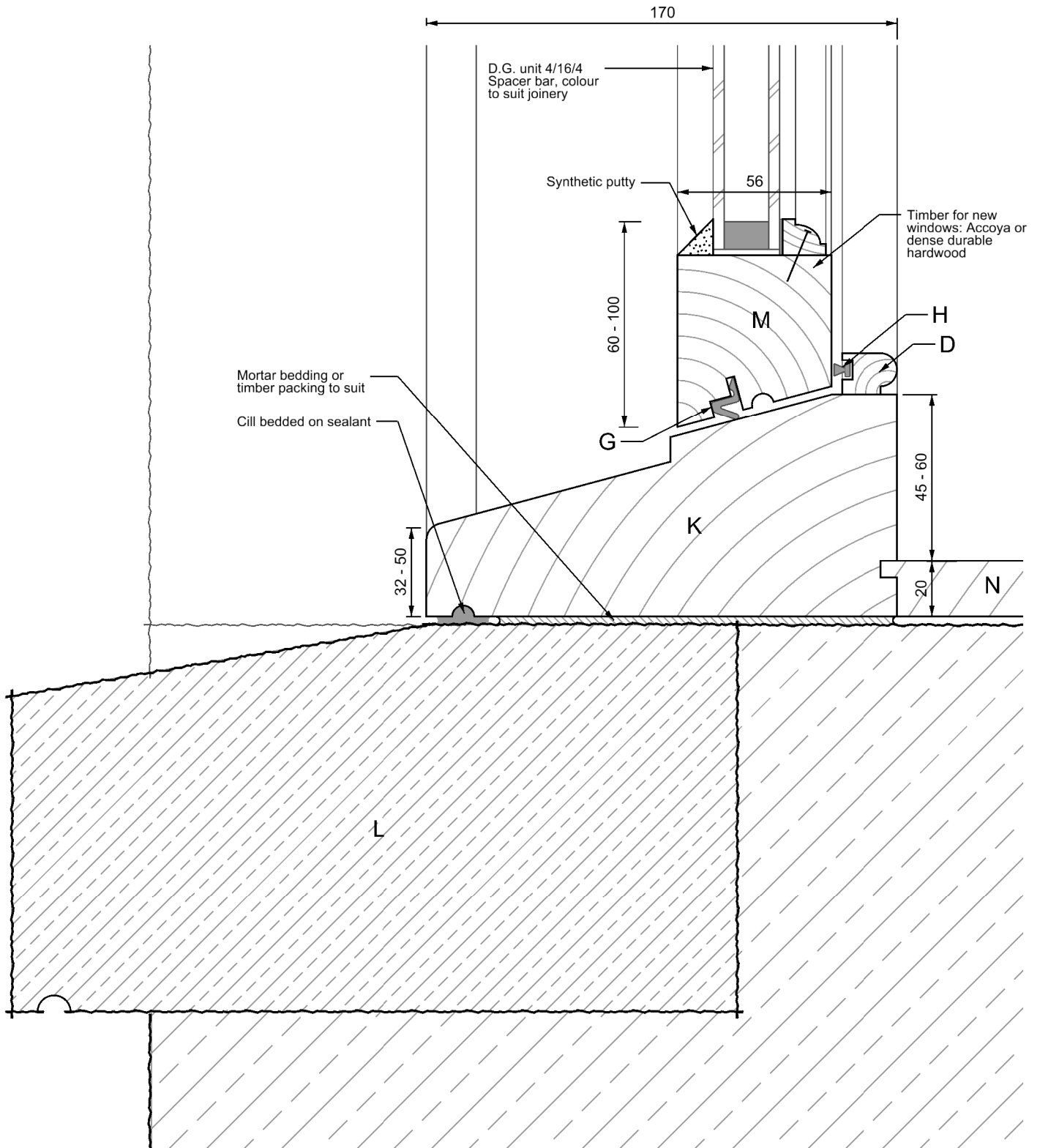

These drawings are intended for guidance only

Sheet: V(A)-DG-Stand-01
Style: VICTORIAN SASH WINDOW
Glazing: Double Glazed (Standard 4/16/4)
Drawing: Cill
Scale: 1:2 @ A4

A	OUTER LINING	K	TIMBER CILL (HARD WOOD OR ACCOYA)
B	INNER LINING	L	STONE CILL
C	SOFFIT LINING	M	BOTTOM RAIL
D	STAFF BEAD	N	WINDOW BOARD
E	PARTING BEAD	O	GLAZING BAR
F	TOP RAIL	P	SASH STILE
G	AQUAMAC 21 DRAUGHT SEAL OR EQUIVALENT	Q	PULLEY STILE
H	DRAUGHT STRIP	R	SASH WEIGHTS (CAST IRON OR LEAD)
I	GLAZING PUTTY	S	SEALANT POINTING
J	MEETING RAILS		

Appendix B: Typical glazing bar mouldings

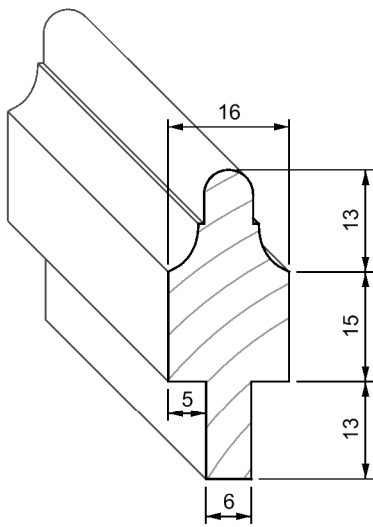

CAVETTO AND BEAD

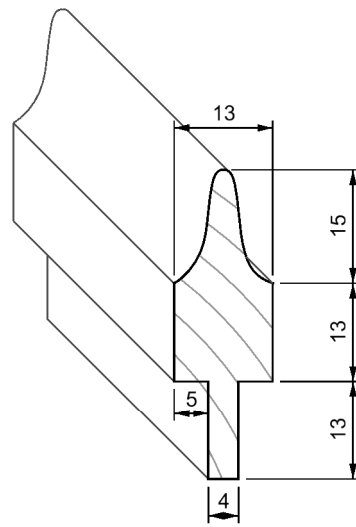

LAMB'S TONGUE

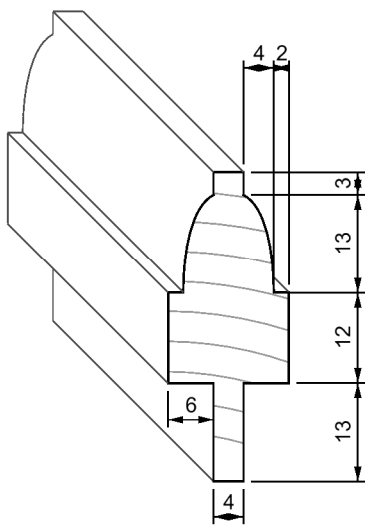

QUADRANT SASH OVOLO

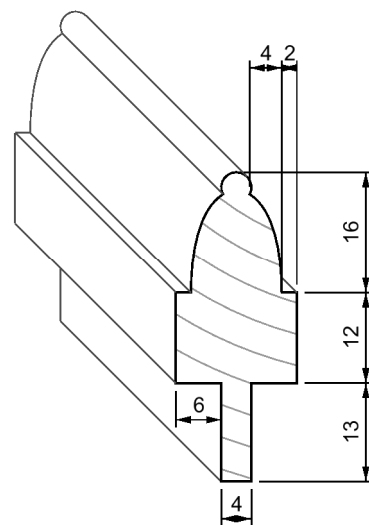

GOTHIC

Sheet: Mouldings
 Drawing: Typical Moulding Profiles
 Scale: 1:1 @ A4



These drawings are for guidance only

Appendix C: Sash horn profiles

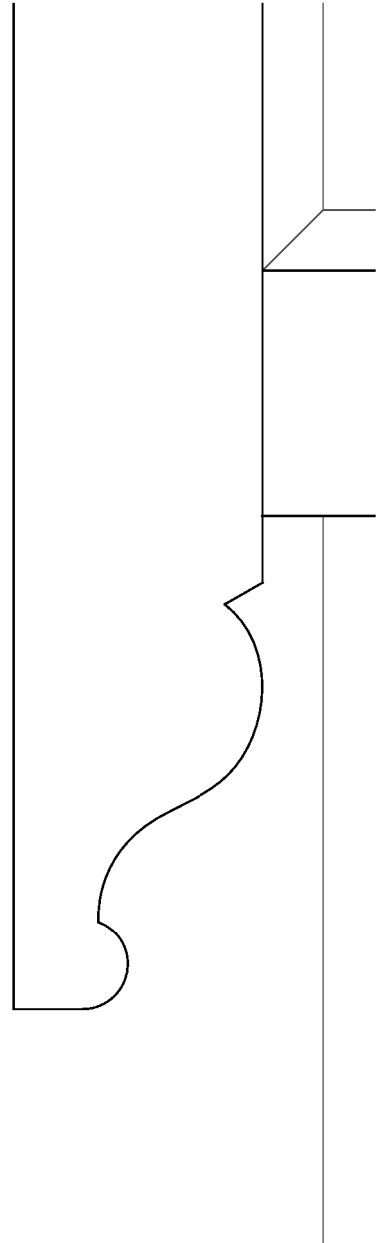
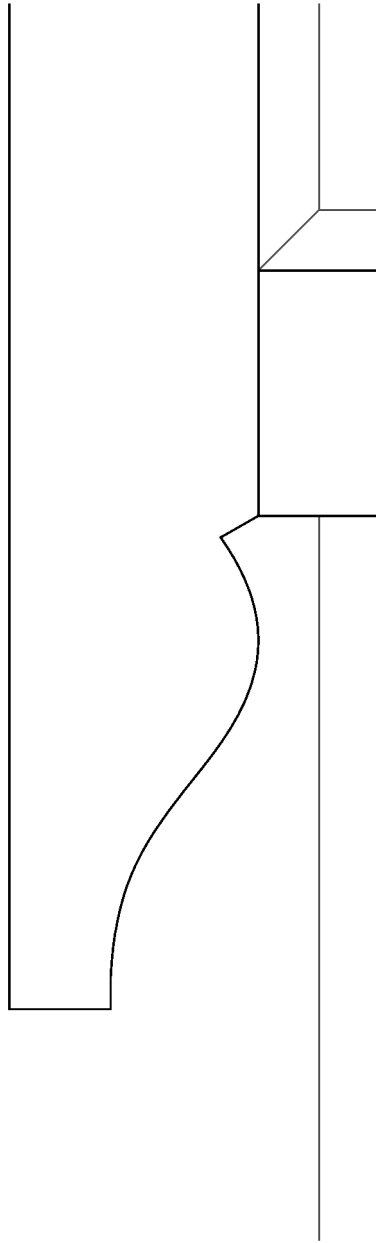
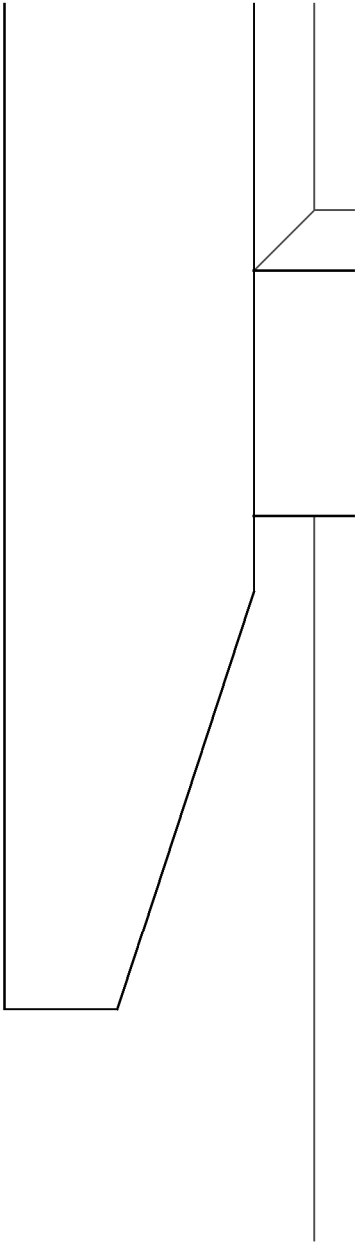

Sheet: SashHorns-01
Drawing: Typical Horns
Scale: 1:1 @ A4



This drawing is for
guidance only

Further advice

Historic England:

General:

<https://historicengland.org.uk/images-books/publications/traditional-windows-care-repair-upgrading/>

Draught proofing:

<https://historicengland.org.uk/images-books/publications/eehb-draught-proofing-windows-doors/>

Secondary glazing:

<https://historicengland.org.uk/images-books/publications/eehb-secondary-glazing-windows/>

Modifying Historic Windows as Part of Retrofitting Energy-Saving Measures:
<https://historicengland.org.uk/whats-new/features/climate-change/modifying-historic-windows-as-part-of-retrofitting-energy-saving-measures/>

Heritage Statement guidance:

<https://historicengland.org.uk/images-books/publications/statements-heritage-significance-advice-note-12/>

Historic Environment Scotland:

Short Guide for Homeowners:

<https://www.historicenvironment.scot/archives-and-research/publications/publication/?publicationId=9ea41caf-aa32-4827-ba08-a59100fea1a3>

Further reading:

[The Thermal Upgrading of Fenestration \(buildingconservation.com\)](http://buildingconservation.com)

Lancaster City Council:

Listed buildings:

<https://www.lancaster.gov.uk/planning/conservation/listed-buildings>

Conservation areas:

<https://www.lancaster.gov.uk/planning/conservation/conservation-areas>

Heritage statements:

<https://www.lancaster.gov.uk/planning/conservation/heritage-statements>